



CAUTION: CAREFULLY READ INSTRUCTIONS BEFORE PROCEEDING

OVERVIEW

The WEGO IIID Rack Pack is a complete kit intended for individual cylinder air/fuel ratio (AFR) monitoring of V8 race engines. Four dual channel WEGO IIID units are connected to an existing data acquisition system.

MOUNTING

Two WEGO IIID units are required for each cylinder bank. The individual units can be secured by means of two #8 screws through the mounting flanges. Mount the units as far away as possible from the ignition system. Use nylon tie wraps to secure the wire harness near the units.

WIRING HOOKUP

If your race vehicle uses any type of CD (capacitive discharge) ignition such as the MSD 6, 7, or 8 series, you must properly ground and filter the ignition unit. **Unless your ignition unit is directly connected to the battery terminals, you must install a filter capacitor such as MSD P/N 8830 or the 12000 uF 25 volt part described in the next paragraph.** Visit www.msdisignition.com, download the MSD 8 installation instructions, and refer to Figure 1 on the MSD instructions as a guide for installing the filter capacitor and grounding the ignition system. Do not ground your WEGO IIID units or data acquisition system to the same ground point used for the ignition system.

CAUTION: The output of the WEGO IIID is a low level 0-5 volt analog signal. Noise from an improperly grounded and filtered race ignition system will cause data acquisition errors.

WEGO IIID units use a switching power supply that draws a peak current near 6 amps. **When multiple units share the same power and ground connections, a filter capacitor is required.** Refer to

Figure 1. For a V8 application with two banks of two WEGO IIID units, use one filter capacitor for each bank. We recommend a 12,000 uF 25 volt filter capacitor (dimensions are 1-3/8"D x 2-1/8"L). Filter capacitors (P/N 75-36DY123F025AA2A) and mounting brackets (P/N 539-VR3) are available from Mouser (phone: 800-346-6873 or www.mouser.com).

For each bank, connect the two WEGO IIID red and heavy black wires to the filter capacitor using the supplied #10 ring tongue terminals. Connect the capacitor+ terminal to switched power using minimum 18 AWG wire. Connect the capacitor- terminal to a good chassis ground location using minimum 16 AWG wire. Connect the WEGO IIID thin black wires to the same point that the data acquisition system is grounded. Keep all power and ground connections as short as possible.

The WEGO IIID Race Pack is supplied with oxygen sensor extension cables. One end of the cable is not terminated. Loose Deutsch connector parts are supplied to allow cutting the extension cables to the required length for a custom installation. Plan the installation carefully. To avoid electrical noise problems, route the cables along frame rails or other metal chassis parts and at least one foot away from any spark plug wires or ignition coil connections. You will require a proper Deutsch crimping tool such as P/N DTT-16-00 available from Ladd Industries (phone: 1-800-223-1236). Follow the color chart below:

Terminal	Wire Color
1	Red
2	Black
3	Brown
4	White
5	Green
6	Seal

Figure 1 – Typical Hookup for Multiple WEGO IIID Systems

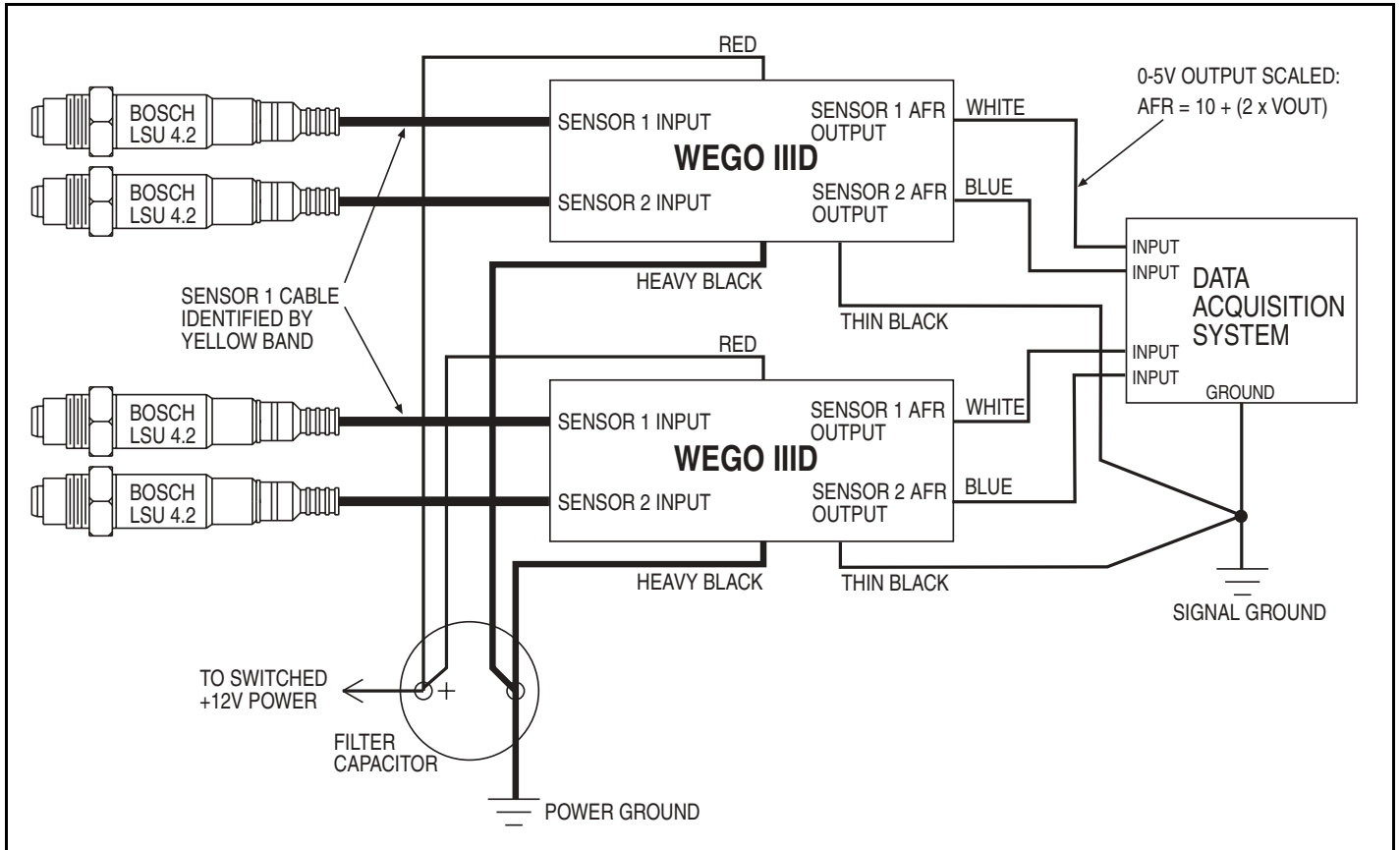

SENSOR INSTALLATION

The Bosch LSU 4.2 sensors should be located on the header pipes about 6-8 inches from the head flange. Ideally the sensor tip should face down to avoid accumulation of condensation. When choosing a mounting location, allow several inches clearance for the sensor wire harness. The wire harness must exit straight out from the sensor. Do not loop the harness back onto the sensor body.

18 x 1.5 mm weld nuts must be welded onto the header pipes. After welding, run an 18 x 1.5 mm tap through the threads. Failure to clean the threads may result in sensor damage. Do not install the sensors until after the free air calibration procedure described in the WEGO IIID instructions. Always use an anti-seize lubricant such as Permatex 133A on the sensor threads.

DATA ACQUISITION

The 0-5 volt analog outputs (white and blue wires) from the WEGO IIID are compatible with most data acquisition systems that have available analog

inputs. **We do not offer any technical assistance on interfacing to your data acquisition system. You must contact the vendor for support.**

After free air calibration, accuracy of the WEGO IIID system is ± 0.1 AFR over the 10.3-19.5 AFR range. The 0-5 volt analog outputs are scaled:

$$AFR = 10 + (2 \times V_{out}) \quad \text{or}$$

$$V_{out} = (AFR - 10)/2$$

For example, an output of 2.5 volts corresponds to 15.0 AFR. Note that when power is first turned on and the sensors are not yet at their normal operating temperature, the analog outputs are held at less than 0.20 volts. During free air calibration and while the WEGO IIID status LEDs are rapidly blinking, the analog outputs will be near 5.0 volts.

SENSOR LIFE AND CALIBRATION

When used in a racing application with leaded gasoline, sensor life will probably be less than 10 hours. Free air calibration should be performed on a regular basis, such as before the start of every test

session or race event. If free air calibration fails, the sensor should be replaced. Free air calibration must be performed in an environment free of hydrocarbon vapors. Typical race shop environments may prove to be too contaminated. Even outdoors, free air calibration can fail if a carburetor bowl has recently been removed or another vehicle is running nearby. In general, sensors that are at the end of their useful life will fail free air calibration.

The WEGO IIID uses standard Bosch LSU 4.2 sensors used on a VW production application (Bosch P/N 0 258 007 057/058 or VW P/N 021 906 262B). The proprietary VW connector is replaced with a smaller Deutsch DT-04-6P available from Ladd Industries. We offer replacement sensors with the Deutsch connector installed. If you plan to terminate your own sensors, use the following color chart:

Terminal	Wire Color
1	Red
2	Black
3	Yellow
4	White
5	Gray
6	Seal