

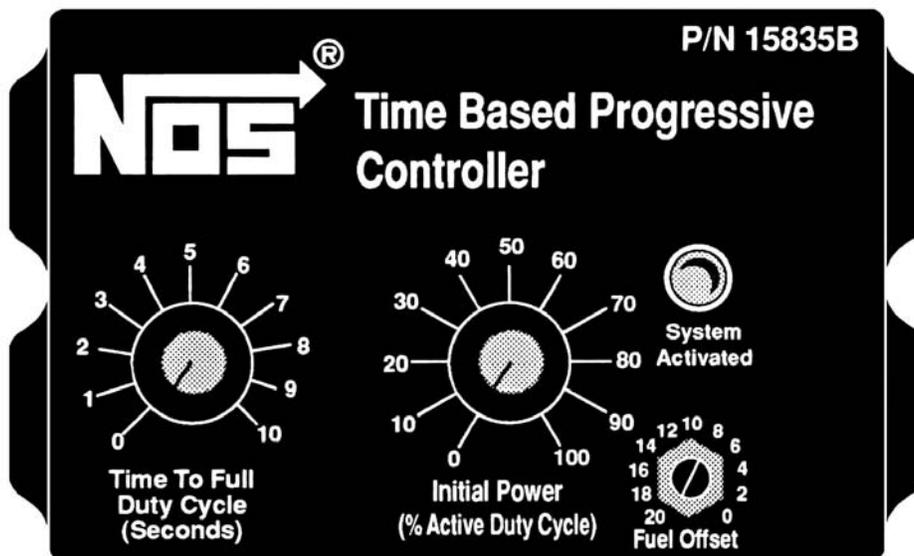

P/N A5074-SNOS

TIME-BASED PROGRESSIVE NITROUS CONTROLLER INSTALLATION INSTRUCTIONS

Kit Number 15835BNOS



OWNER'S MANUAL

NOTICE: Installation of Nitrous Oxide Systems Inc. products signifies that you have read this document and agreed to the terms stated within.

It is the purchaser's responsibility to follow all installation instruction guidelines and safety procedures supplied with the product as it is received by the purchaser to determine the compatibility of the product with the vehicle or the device the purchaser intends to install the product on.

Nitrous Oxide Systems Inc. assumes no responsibility for damages occurring from accident, misuse, abuse, improper installation, improper operation, lack of reasonable care, or all previously stated reasons resulting from incompatibility with other manufacturers' products.

Nitrous Oxide Systems Inc. assumes no responsibility or liability for damages incurred by the use of products manufactured or sold by Nitrous Oxide Systems Inc. on vehicles used for competition or racing.

Nitrous Oxide Systems Inc. neither recommends nor condones the use of products manufactured or sold by Nitrous Oxide Systems Inc. on vehicles, which may be driven on public roads or highways, and assumes no responsibility for damages incurred by such use.

NOS nitrous oxide is legal for use in most states when used in accordance with state and local traffic laws. NOS does not recommend or condone the use of its products in illegal racing activities.

HAZARDS DEFINED

This manual presents step-by-step instructions that describe the process of installing your NOS Nitrous Oxide Injection System. These procedures provide a framework for installation and operation of this kit. Parts are referenced by name and number to avoid confusion. Within the instructions, you are advised of potential hazards, pitfalls, and problems to avoid. The following examples explain the various hazard levels:

WARNING! Failure to comply with instructions may result in injury or death.

CAUTION! Failure to comply with instructions may result in damage to equipment.

NOTE: This information is important, needs to be emphasized, and is set apart from the rest of the text.

HINT: These special instructions provide a handy work tip.

NITROUS OXIDE INJECTION SYSTEM SAFETY TIPS

WARNINGS

Do not attempt to start the engine if the nitrous has been injected while the engine was not running. Disconnect the coil wire and turn the engine over with the throttle wide open for several revolutions before attempting to start. Failure to do so can result in extreme engine damage.

Never permit oil, grease, or any other readily combustible substances to come in contact with cylinders, valves, solenoids, hoses, and fittings. Oil and certain gases (such as oxygen and nitrous oxide) may combine to produce a highly flammable condition.

Never interchange nitrous and fuel solenoids. Failure to follow these simple instructions can result in extreme engine damage and/or personal injury.

Never drop or violently strike the bottle. Doing so may result in an explosive bottle failure.

Never change pressure settings of safety relief valve on the nitrous bottle valve. Increasing the safety relief valve pressure settings may create an explosive bottle hazard.

Identify the gas content by the NOS label on the bottle before using. If the bottle is not identified to show the gas contained, return the bottle to the supplier.

Do not deface or remove any markings, which are on the nitrous bottle.

Nitrous bottle valves should always be closed when the system is not being used.

Notify the supplier of any condition, which might have permitted any foreign matter to enter the valve or bottle.

Keep the valves closed on all empty bottles to prevent accidental contamination.

After storage, open the nitrous bottle valve for an instant to clear the opening of any possible dust or dirt.

It is important that all threads on the valves and solenoids are properly mated. Never force connections that do not fit properly.

CONGRATULATIONS on purchasing your NOS Nitrous Oxide Injection System. Your system is composed of the highest quality components available. It should provide many miles of trouble-free performance when used correctly. If you have any questions regarding the performance of your system, call NOS Technical Service at 1-866-GOHOLLEY.

TABLE OF CONTENTS

What is Nitrous Oxide?	4
Do's and Don'ts of Nitrous Oxide	4
Chapter 1 Introduction to Your Progressive Nitrous Controller	4
1.1 General Information	4
1.2 Operating Principle	5
1.3 System Requirements (Wet Manifold Systems)	5
1.4 Kit Components	5
Chapter 2 Installation	7
2.1 Redundant Nitrous Solenoid	7
2.1.A Wet Manifold Powershot/Super Powershot	7
2.1.B Wet Manifold Cheater/Big Shot/Pro Shot	7
2.2 Control Module Mounting	8
2.3 System Wiring	8
2.3.1 Dry Manifold Systems	8
2.3.2 Wet Manifold Systems (One Nitrous & One Fuel Solenoid)	10
2.3.3 Wet Manifold Systems (Two Nitrous & Two Fuel Solenoids)	11
Chapter 3 Preparing for Operation	13
3.1 System Checkout	13
Chapter 4 Tuning Suggestions	14
4.1 Advanced Tuning Concepts	14
4.2 Adjusting Initial Power Incr. & the Rate at which Add. Power is Applied	14
Chapter 5 Routine Maintenance	15
5.1 Solenoid Inspection and Maintenance	15
Appendix A Troubleshooting Guide	16

LIST OF FIGURES AND TABLES

Figure 1 Time-Based Progressive Controller Kit #15835BNOS—Component Identification	6
Figure 2 Installation Kit #0050NOS—Component Identification—All Wet Manifold Systems: Power shot, Super Powershot, Cheater, Big Shot, & Pro Shot Fogger	6
Figure 3 Exploded View of Redundant Nitrous Solenoid Installation—All Wet Manifold Systems: Powershot, Super Powershot, Cheater, Big Shot, & Pro Shot Fogger	7
Figure 4 Throttle Microswitch Installation	8
Figure 5 Wiring Diagram (Dry Manifold Systems—Two Nitrous Solenoids)	9
Figure 6 Throttle Microswitch Installation	10
Figure 7 Wiring Diagram (Wet Manifold Systems—One Nitrous & One Fuel Solenoid)	11
Figure 8 Throttle Microswitch Installation	12
Figure 9 Wiring Diagram (Wet Manifold Systems—Two Nitrous & Two Fuel Solenoids)	13
Figure 10 Tuning Map—Solenoid Duty Cycle (Power) versus Time	14
Figure 11 Powershot/Super Powershot Solenoid Exploded View	15
Figure 12 Cheater/Big Shot/Pro Shot Solenoid Exploded View	15
Figure 13 Solenoid Seal	16
Table 1 Time-Based Progressive Controller Kit #15835BNOS—Parts List	5
Table 2 Installation Kit #0050NOS—Parts List—All Wet Manifold Systems: Powershot, Super Powershot, Cheater, Big Shot, & Pro Shot Fogger	6
Table 3 Solenoid Rebuild Kit Part Numbers	16

WHAT IS NITROUS OXIDE?

NITROUS OXIDE...

- ...Is a cryogenic gas composed of nitrogen and oxygen molecules
- ...Is 36% oxygen by weight
- ...Is non-flammable by itself
- ...Is stored as a compressed liquid

...Exists in two grades—U.S.P. and Nitrous Plus:

- U.S.P. is medical grade nitrous oxide; its common use is dental and veterinary anesthesia. It is also commonly used as a propellant in canned whipped cream. U.S.P. is not available to the public.
- Nitrous Plus differs from U.S.P. in that it contains trace amounts of sulphur dioxide added to prevent substance abuse. Nitrous Plus is intended for automotive applications and is available for sale to the public

In automotive applications, Nitrous Plus and fuel are injected into the engine's intake manifold, which produces the following results:

- Lowers engine intake air temperature, producing a dense inlet charge.
- Increases the oxygen content of the inlet charge (air is only 22 percent oxygen by weight).
- Increases the rate at which combustion occurs in the engine's cylinders.

Do's and Don'ts of Nitrous Oxide

Do's

- Read all instructions before attempting to install your NOS nitrous system.
- Make sure your fuel delivery system is adequate for the nitrous jetting you have chosen. Inadequate fuel pressure or flow will result in engine damage. Modified engines may require a larger (higher pressure/volume) fuel pump than originally installed by Honda/Acura.
- Use Teflon-based **paste** on pipe style fittings.
- Make sure your engine and related components (ignition and driveline) are in proper working condition.
- If nitrous is accidentally injected into the engine when it is not running, remove the engine coil wire, open the throttle, and crank the engine 10 to 15 seconds before starting. Failure to do so can result in an explosive engine failure.**
- Activate your NOS nitrous system only at engine speeds as outlined in your systems owner's manual.**
- Install a proper engine to chassis ground. Failure to do so may result in an explosive failure of the main nitrous supply line.**

Don'ts

- Engage your nitrous system with the engine off. **Severe** engine damage can occur.
- Modify NOS nitrous systems (if you need a non-stock item, call NOS Technical Service for assistance).
- Overtighten AN type fittings.
- Use Teflon Tape on any pipe threads. Pieces of Teflon tape can break loose and become lodged in nitrous or fuel solenoids or solenoid filters. Debris lodged in a nitrous or fuel solenoid can cause catastrophic engine failure.



- Use sealant of any kind on AN type fittings.
- Allow nitrous pressure to exceed 1100 psi. Excessive pressure can cause swelling or in extreme cases, failure of the nitrous solenoid plunger. Solenoid plungers are designed so that pressure-induced failures will prevent the valve from operating. No leakage should occur with this type of failure.
- Inhale nitrous oxide. Death due to suffocation can occur.**
- Allow nitrous oxide to come in contact with skin. Severe frostbite can occur.**

Chapter 1 Introduction to your NOS Nitrous Oxide Kit

1.1 General Information

Your NOS Progressive Nitrous Oxide Injection Controller is designed to provide you with an ability to "adjust" the rate at which power from your nitrous oxide injection kit is applied to your vehicle. This controller is capable of operating any NOS nitrous system that features the nitrous and fuel solenoids with a maximum combined current draw of 40 amps, not including safety solenoids. Note that the highest current draw of any standard single stage NOS system is approximately 23-30 amps (NOS Pro Fogger P/N 02462NOS).

Initial power (solenoid duty cycle) is adjustable from 0-100%. The rate at which the solenoid duty cycle is increased (power increased) is adjustable from 0-10 seconds. Maximum power is adjusted through jetting changes, similar to a conventional nitrous oxide injection system.

The time-based progressive nitrous controller is applicable to a variety of vehicles using the NOS nitrous oxide injection kits. The basic controller and operating principle is the same for your vehicle regardless of whether it is carbureted or equipped with electronic fuel injection. However, the mounting hardware necessary for a safe installation varies with application. Listed below are the three types of nitrous oxide injection kits produced by NOS, and the application kits necessary for a proper installation.

1) "Dry Manifold EFI Kits"

These are systems that are characterized by their use of 2 nitrous solenoids and no fuel solenoids. Vehicles that use this type of system are typically late model fuel injected vehicles with return style fuel systems. No application kit is necessary for these vehicles.

2) “Wet Manifold Powershot/Super Powershot/Cheater/Big Shot Kits”

These are systems that use 1 fuel and 1 nitrous Super Powershot/Cheater/Pro Shot/ Super Pro Shot solenoid. One installation kit P/N 0050 is required.

3) “Wet Manifold Sportsman Fogger/Pro Shot Fogger Kits”

These are systems that use 3 fuel and 2 nitrous Super Powershot/Cheater/Pro Shot solenoids. Two installation kits P/N 0050 are required.

Controller Operating Status

Included in the features of this unit is an LED indicator light on the front panel of the control unit. Controller status can be monitored via this light. The operating status is as follows:

- 1) No light—Controller is unarmed.
- 2) Light Flashing Steadily (Approximately twice per second)—System is armed and ready for use.
- 3) Light is on—Controller is active, and nitrous system is on.
- 4) Light Flashing Steadily (Approximately twice per second)—Controller is active, nitrous system has been activated, and then deactivated (throttle has been released, and the nitrous system is still armed).
- 5) Disarming and re-arming the system resets the controller. The controller must be reset after any settings are changed.

Fuel Solenoid Offset

Some high output wet manifold systems can encounter a stumble upon activation if a very low initial power setting is chosen and/or a low battery voltage situation is encountered. In these circumstances, decreasing the initial Fuel Solenoid duty cycle relative to the starting Nitrous Solenoid duty cycle can eliminate this stumble. Refer to Chapter 4 for specific details.

This controller is configured to manipulate nitrous and fuel solenoids using the technique known as “pulse width modulation”. Solenoids are opened, held open for a specific period of time (measured in milliseconds), and closed 35 times per second, up until the time 100% power setting is reached (equivalent to a solenoid duty cycle of .029 seconds or 29 milliseconds). At that time, the solenoids lock open until the system is de-energized. The amount of time the solenoids are held open is varied proportional to the settings (Initial Power and Time to Full Power) that you select using the controller’s knobs. When using this controller with systems that feature nitrous and/or fuel jetting whose total cross sectional area is significantly smaller than the area of the nitrous or fuel solenoid orifices, full power may be reached significantly quicker than the settings you have selected with the controller knobs.

1.2 Operating Principle

Dry Manifold Style NOS Systems

In Dry Manifold style NOS nitrous oxide injection kits, the #1, or upstream solenoid works as a safety solenoid, preventing the accidental leakage of nitrous oxide into the engine if the #2 solenoid (the unit being modulated) were to experience premature degradation of the solenoid plunger seat.

Wet Manifold Carbureted and EFI Fogger Nozzle Style NOS Systems

A secondary or redundant solenoid must be used on the nitrous side of the system as a safety feature. When the timer is activated, the secondary solenoid opens 100% and stays open until the throttle switch is deactivated. Once the throttle switch is deactivated, this secondary solenoid also closes, preventing accidental leakage of nitrous oxide into the engine.

1.3 System Requirements (Wet Manifold Systems)

*Redundant Solenoid—When used with a wet manifold or “Fogger” style system, one secondary or redundant solenoid must be used for each nitrous solenoid.

WARNING! Due to the cyclic nature of the solenoid operation, use of this kit will reduce the life expectancy of the primary nitrous solenoid plunger. Do not attempt to operate this system without the redundant nitrous solenoid in place. Doing so can result in leakage of nitrous oxide into the engine and catastrophic engine explosion, resulting in injury or death.

1.4 Kit Components

Before beginning the installation of your NOS kit, compare the components in your kit with those illustrated in Figure 1 and listed in Table 1. If any components are missing, please contact NOS Technical Support at 1-866-GOHOLLEY.

If installing this system on a engine equipped with a “Wet Manifold System”, compare the components in your installation kit(s) with those illustrated in Figure 2 and listed in Table 2.

NOTE: Remember, when using the Time-Based Nitrous Controller with a Wet Manifold Nitrous System, you must use one installation kit for each nitrous solenoid.

Table 1 Time-Based Progressive Controller #15835BNOS—Parts List

Item	Description	Quantity	NOS P/N
(1)	Control Module	1	15835B-S
(2)	Wire Connector	6	15880-S
(3)	Male Spade Connector (Green)	7	15888G-S
(4)	Female Spade Connector (Red)	3	15885R-S
(5)	Small Eyelet	6	15881-S
(6)	Female Spade Connector (Red)	2	15889R-S
(7)	Scotch Lock Connector	1	15891-S
(8)	Large Eyelet	1	15883-S

Figure 1 Time-Based Progressive Controller Kit #15835BNOS—Component Identification

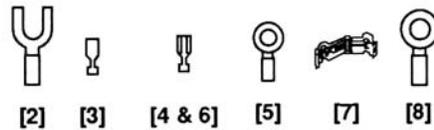
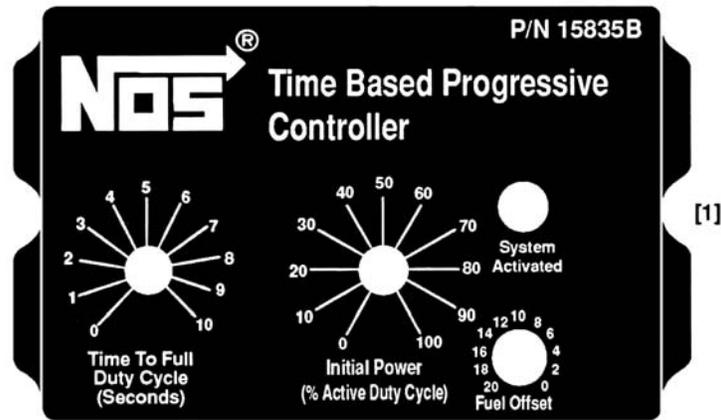
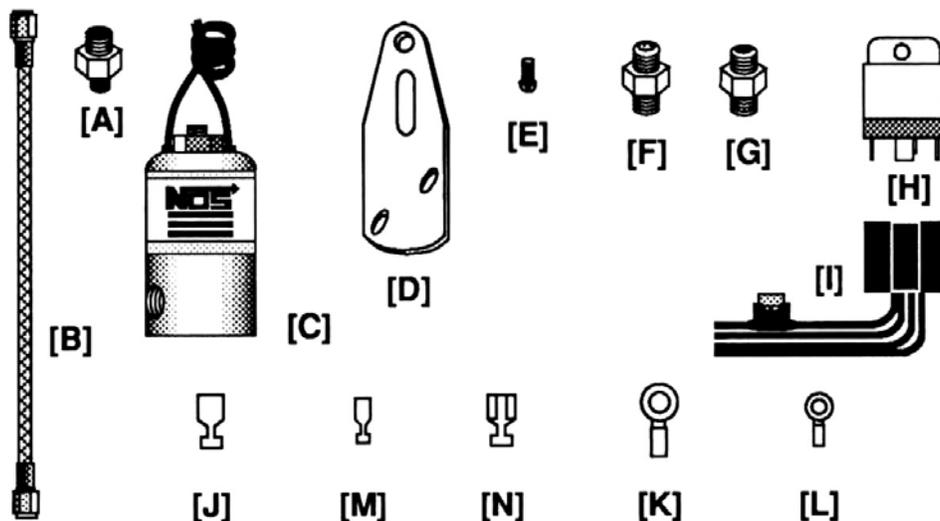

Table 2 Installation Kit #0050NOS—Parts List—All Wet Manifold Systems: Powershot, Super Powershot, Cheater, Big Shot, and Pro Shot Fogger.

Item	Description	Quantity	NOS P/N
(A)	1/8" NPT x 4AN Adapter Fitting	2	17960-S
(B)	1 ft. 4AN Hose (Blue)	1	15210-S
(C)	Pro Shot Nitrous Solenoid	1	16040-S
(D)	Solenoid Mounting Bracket	1	16500-S
(E)	Solenoid Mounting Screws	2	16501-S
(F)	1/4" NPT x 4AN Nitrous Filter	1	15560-S
(G)	4AN x 1/4" NPT Fitting	1	17970-S
(H)	Relay (#2)	1	15618-S
(I)	Relay Harness	1	15604-S
(J)	Large Male Spade	2	15886B-S
(K)	Large Eyelet	1	15883-S
(L)	Small Eyelet	1	15881-S
(M)	Small Male Spade	2	15888G-S
(N)	Large Female Spade	1	15885B-S
(O)	Wiring Pack	1	----

Figure 2 Installation Kit #0050NOS—Component Identification—All Wet Manifold Systems: Powershot, Super Powershot, Cheater, Big Shot, and Pro Shot Fogger.



Chapter 2 Installation

2.1 Redundant Nitrous Solenoid

2.1.A Redundant Nitrous Solenoid (Wet Manifold: Powershot, Super Powershot, and Sportsman Fogger Systems)

NOTE: Refer to Figure 3 while performing installation procedures.

1. Remove the nitrous filter fitting from the inlet of the primary nitrous solenoid (pre-existing systems).
2. Install the 1/8" NPT x 4AN fitting (A) in the primary nitrous solenoid inlet port.
3. Attach the 1 ft. 4AN Hose (B) to the fitting installed in the primary nitrous solenoid inlet port.
4. Place the redundant nitrous solenoid (C) in a bench vise.
5. Install the nitrous filter (F) in the inlet port of the redundant solenoid.
6. Install the 1/8" x 4AN fitting (A) in the outlet port of the redundant solenoid.
7. Remove the solenoid from the vise. Choose the mounting location for the redundant nitrous solenoid. The redundant nitrous solenoid must be located where the 1 ft. 4AN Hose will reach the primary nitrous solenoid inlet port.
8. Secure the redundant solenoid with the mounting bracket (D) and the screws (E).
9. Connect the 1 ft. 4AN Hose to the fitting installed in the redundant nitrous solenoid outlet port.
10. Repeat steps 1 through 9 for Wet Manifold systems that use two nitrous solenoids.

Figure 3 Exploded View of Redundant Solenoid Installation on ALL Wet Manifold Systems

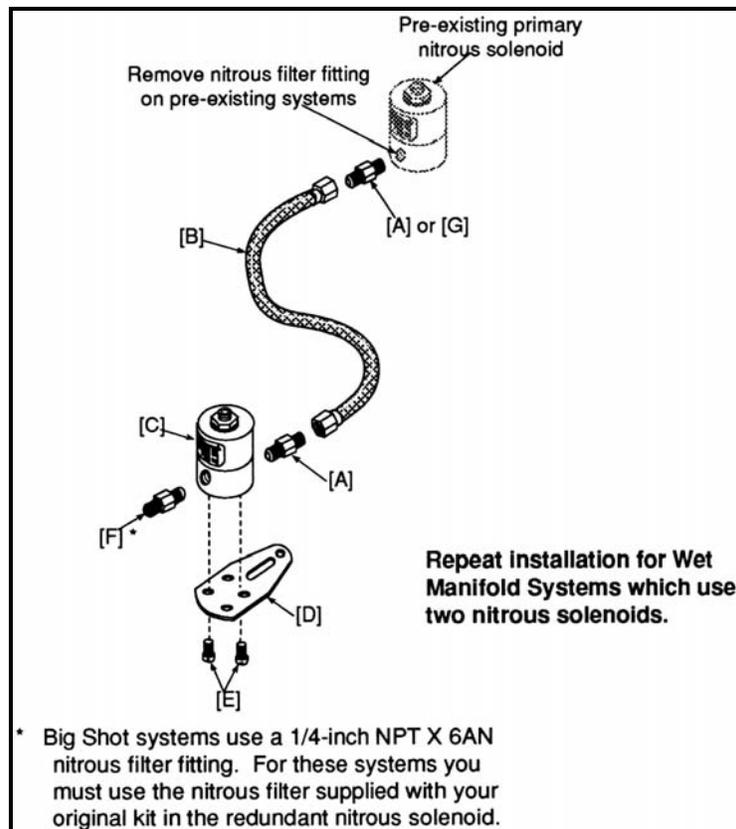

2.1.B Redundant Nitrous Solenoid (Wet Manifold Cheater/Big Shot and Pro Shot Systems)

NOTE: Refer to Figure 3 while performing installation procedures.

1. Remove the nitrous filter fitting from the inlet of the primary nitrous solenoid inlet port (pre-existing systems).
2. Install the 1/4" NPT x 4AN fitting (G) in the primary nitrous solenoid inlet port.

3. Attach the 1 ft. 4AN Hose (B) to the fitting installed in the primary nitrous solenoid inlet port.
4. Place the redundant nitrous solenoid (C) in a bench vise.
5. Install the nitrous filter (F) in the inlet port of the redundant solenoid.

NOTE: Big Shot systems use a 1/4" NPT x 6AN nitrous filter fitting. For these systems, you must use the nitrous filter supplied with your original kit in the redundant nitrous solenoid.

6. Install the 1/8" NPT x 4AN fitting (A) in the outlet port of the redundant solenoid.
7. Remove the solenoid from the vise. Choose the mounting location for the redundant nitrous solenoid. The redundant nitrous solenoid must be located where the 1 ft. Hose will reach the primary nitrous solenoid inlet port.
8. Secure the redundant solenoid with the mounting bracket (D) and the screws (E).
9. Connect the 1 ft. 4AN Hose to the fitting installed in the redundant nitrous solenoid outlet port.
10. Repeat steps 1 through 9 for Wet Manifold systems that use 2 nitrous solenoids.

2.2 Control Module Mounting

Locate a suitable mounting location within the interior of the vehicle for the control module (1). The control module should not be mounted near the ignition components, or exposed to extreme heat. Secure in place.

HINT: Lay out all the wiring leads before securing the control module in place to ensure that the leads reach the components.

2.3 System Wiring

2.3.1 System Wiring (Dry Manifold Systems)

NOTE: If the nitrous system that this kit is to be used in conjunction with has been previously installed, the original wiring must be removed and replaced. Refer to Figure 5 for the wiring diagram.

1. Disconnect the vehicle's battery.
2. If you have not yet installed the throttle microswitch that you received with your system, install it now using steps 3a-3c.

WARNING! Binding or dragging of the throttle linkage will create a potentially dangerous stuck-throttle condition. Ensure that the microswitch does not interfere with the normal throttle linkage operation.

NOTE: The microswitch may be mounted to the bracket in a variety of positions and on either side of the bracket. The bracket may be bent to suit your application.

3. Install the throttle microswitch as follows:
 - A. Mount the throttle microswitch on the throttle body, so the throttle linkage movement triggers the microswitch.
 - B. Adjust the microswitch to trigger at wide-open throttle by adjusting the microswitch's position to ensure the actuation arm of the microswitch "clicks" at the same point the throttle linkage reaches wide-open throttle against the throttle stop (Position A).
 - C. Ensure the throttle and switch can reach the activation position shown in Position B by using the accelerator pedal. Have an assistant slowly press the pedal to the floor while you listen for the "click" of the microswitch.

Figure 4 Throttle Microswitch Installation

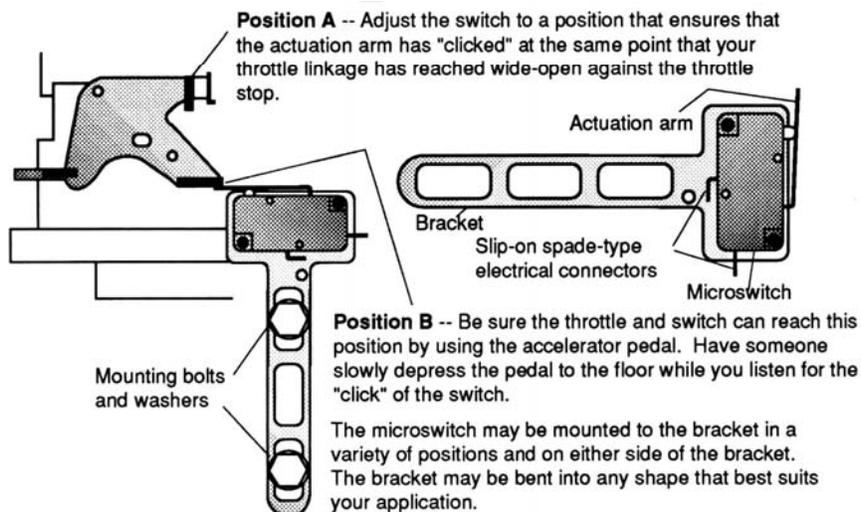

- Connect the terminal on the controller marked "BAT" to the blue wire on the relay using the blue 14 Ga. wire provided.

NOTE: The current draw through this circuit is minimal (1-2 amps). NOS suggests that this terminal be connected to an Ignition switched +12V circuit, to prevent the controller from being activated with the vehicle's ignition off.

NOTE: This wiring scheme employs the existing relay and arming switch from your nitrous system.

- Connect the orange wire from the relay to the ignition switched 12V source.
- Connect the red wire from the relay to the #2 terminal on the arming switch.
- Connect the #1 terminal on the arming switch to the ignition switched 12V source.
- Connect the #3 terminal on the arming switch to the ground.
- Connect the green wire on the relay to the ground.
- Connect the terminal marked "SW" to one terminal on the wide-open throttle microswitch, using the black 14 gauge wire.
- Connect the remaining terminal on the wide-open throttle microswitch to the ground, using the black 14 gauge wire.

Figure 5 Wiring Diagram (Dry Manifold Systems with Two Nitrous Solenoids)

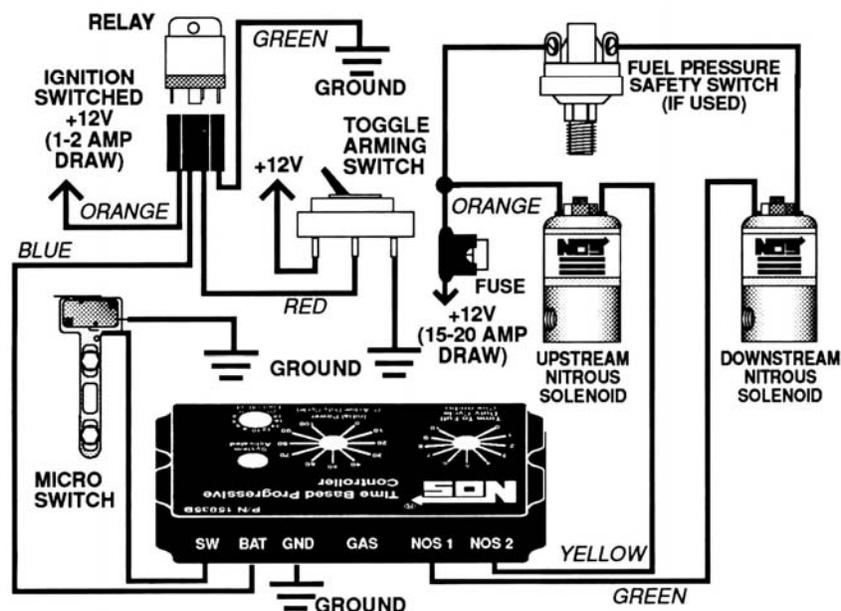

- Connect the controller terminal marked "GND" to a good chassis ground using the orange 12 gauge wire.

NOTE: The entire current draw of the nitrous and fuel solenoid will pass through this terminal and wire. Be sure that you select an adequate ground or your system will not operate correctly.

- Connect the terminal marked "NOS 2" to one wire from the secondary or upstream nitrous solenoid (solenoid valve that is connected directly to the nitrous oxide storage cylinder), with the yellow wire provided.
- Connect the terminal marked "NOS 1" to one wire from the primary or downstream nitrous solenoid (solenoid valve that is connected directly to the engine's nitrous discharge nozzle), with the green wire provided.

NOTE: Step 15A is for systems that DO NOT use a fuel pressure safety switch.

- Connect the remaining wire from each nitrous solenoid to a +12V source, with the fused orange wire provided.

NOTE: 15B.1 and 15B.2 are for systems that employ a fuel pressure safety switch.

- Connect the remaining wire from the downstream nitrous solenoid to one terminal on the fuel pressure safety switch.
- Connect the open terminal on the fuel pressure safety switch and the remaining wire from the upstream solenoid to a +12V source, with the fused orange wire provided.

NOTE: When selecting a +12V source, keep in mind that the entire current draw from two nitrous solenoids approaches 20 amps. Connecting directly to the battery or some other circuit with high amp capability, such as a starter relay, is suggested.

- Install 20 amp fuse in the fuse holder.

2.3.2 System Wiring (Wet Manifold Systems with One Nitrous and One Fuel Solenoid)

NOTE: If the nitrous system that this kit is to be used in conjunction with has been previously installed, the original wiring must be removed and replaced. Refer to Figure 7 for the wiring diagram.

1. Disconnect the vehicle's battery.
2. If you have not yet installed the throttle microswitch that you received with your system, install it now using steps 3a through 3c.

WARNING! Binding or dragging of the throttle linkage will create a potentially dangerous stuck-throttle condition. Ensure that the microswitch does not interfere with the normal throttle linkage operation.

3. Install the throttle microswitch as follows:
 - A. Mount the throttle microswitch on the throttle body, so the throttle linkage movement triggers the microswitch.
 - B. Adjust the microswitch to trigger at wide-open throttle by adjusting the microswitch's position to ensure the actuation arm of the microswitch "clicks" at the same point the throttle linkage reaches wide-open throttle against the throttle stop (Position A).
 - C. Ensure the throttle and switch can reach the activation position shown in Position B by using the accelerator pedal. Have an assistant slowly press the pedal to the floor while you listen for the "click" of the microswitch.

Figure 6 Throttle Microswitch Installation

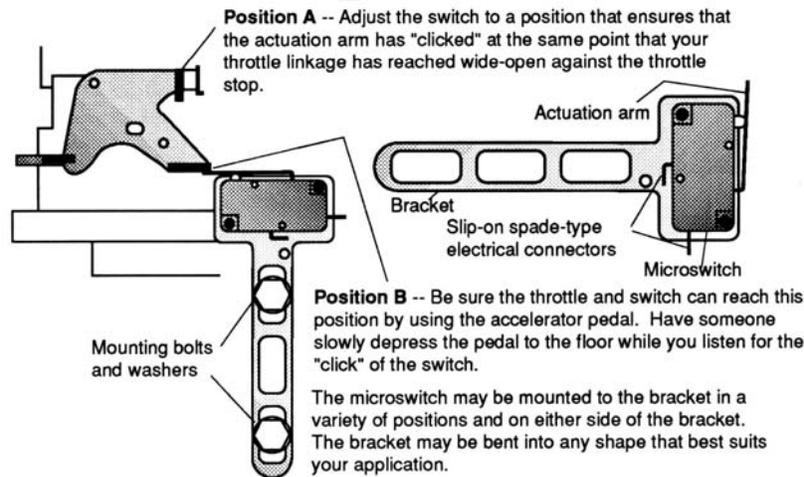

4. Connect the terminal on the controller marked "BAT" to the #2 terminal on your arming switch with the blue wire provided.

NOTE: The current draw through this circuit is minimal (1-2 amps). NOS suggests that this terminal be connected to an ignition switched +12V circuit, to prevent the controller from being activated with the vehicle's ignition off.

5. Connect the #1 terminal on the arming switch to the ignition switched +12V source.
6. Connect the #3 terminal on the arming switch to the ground.
7. Connect the terminal marked "SW" to the one terminal on the wide-open throttle microswitch, using the black 14 gauge wire.
8. Connect the remaining terminal on the wide-open throttle microswitch to the ground, using the black 14 gauge wire.
9. Connect the controller terminal marked "GND" to a good chassis ground using the orange 12 gauge wire.

NOTE: The entire current draw of the nitrous and fuel solenoid will pass through this terminal and wire. Be sure that you select an adequate ground or your system will not operate correctly.

10. Connect the terminal marked "NOS 2" to one wire from the redundant or safety solenoid, with the yellow wire provided.
11. Connect the terminal marked "NOS 1" to one wire from the nitrous solenoid, with the green wire provided.
12. Connect the terminal marked "GAS" to one wire from the fuel solenoid, with the red wire provided.

NOTE: Step 13A is for systems that DO NOT use a fuel pressure safety switch.

- 13A. Connect the remaining wires from the fuel, nitrous, and redundant nitrous solenoid to a +12V source, with the fused orange wire provided.

NOTE: When selecting a +12V source, keep in mind that the entire current draw from two nitrous solenoids and one fuel solenoid approaches 30 amps. Connecting directly to the battery or some other circuit with high amp capability, such as a starter relay, is suggested.

NOTE: Steps 13B.1 and 13B.2 are for systems that employ a fuel pressure safety switch.

- 13B.1 Connect the remaining wire from the fuel and nitrous solenoids to one of the terminals on the fuel pressure safety switch.
- 13B.2 Connect the open terminal on the fuel pressure safety switch and the open wire from the redundant nitrous solenoid to a +12V source, with the fused orange wire provided.
- NOTE:** When selecting a +12V source, keep in mind that the entire current draw from two nitrous solenoids approaches 20 amps. Connecting directly to the battery or some other circuit with high amp capability, such as a starter relay, is suggested.
14. Install a 15 amp fuse in the fuse holder.

Figure 7 Wiring Diagram (Wet Manifold System with One Nitrous and One Fuel Solenoid)

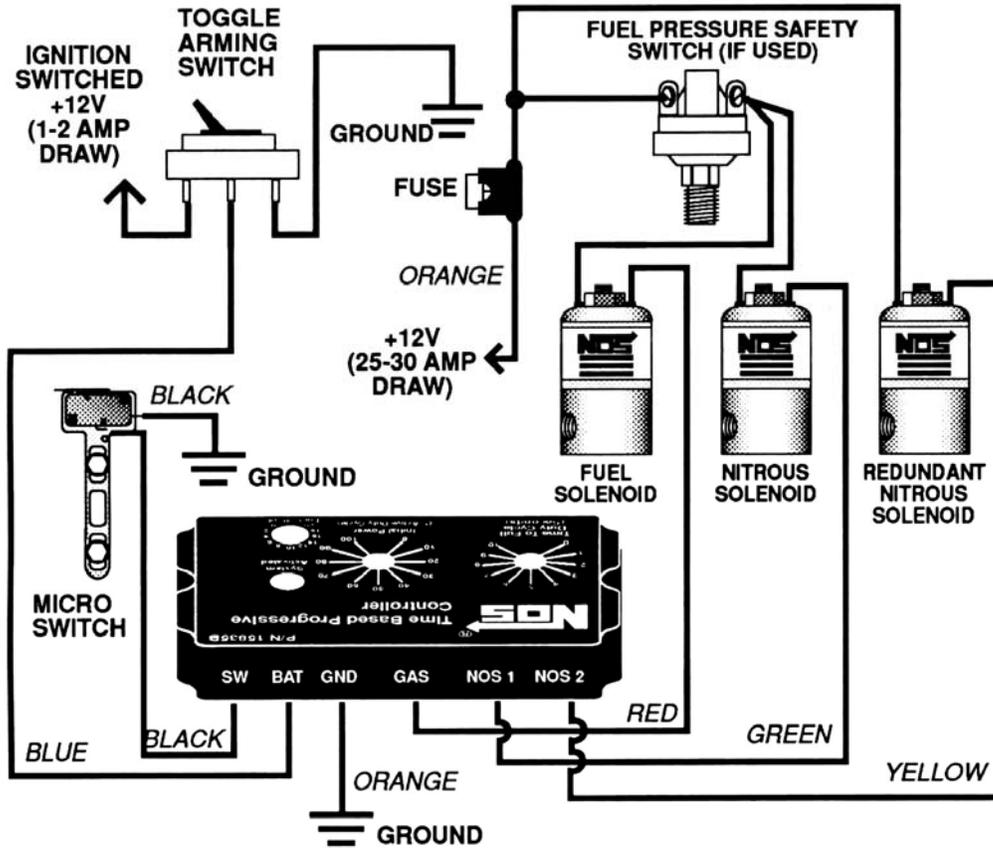

2.3.3 System Wiring {WET Manifold Systems with 4 Solenoids - 2 Nitrous and 2 Fuel}

2.3.3 System Wiring (Wet Manifold Systems with 4 Solenoids—2 Nitrous and 2 Fuel)

NOTE: If the nitrous system that this kit is to be used in conjunction with has been previously installed, the original wiring must be removed and replaced. Refer to Figure 9 for the wiring diagram.

1. Disconnect the vehicle's battery.
2. If you have not yet installed the throttle microswitch that you received with your system, install it now using steps 3a through 3c.

WARNING! Binding or dragging or the throttle linkage will create a potentially dangerous stuck-throttle condition. Ensure that the microswitch does not interfere with the normal throttle linkage operation.

3. Install the throttle microswitch as follows:
 - A. Mount the throttle microswitch on the throttle body, so the throttle linkage movement triggers the microswitch.
 - B. Adjust the microswitch to trigger at wide-open throttle by adjusting the microswitch's position to ensure the actuation arm of the microswitch "clicks" at the same point the throttle linkage reaches wide-open throttle against the throttle stop (Position A).
 - C. Ensure the throttle and switch can reach the activation position shown in Position B by using the accelerator pedal. Have an assistant slowly press the pedal to the floor while you listen for the "click" of the microswitch.

Figure 8 Throttle Microswitch Installation

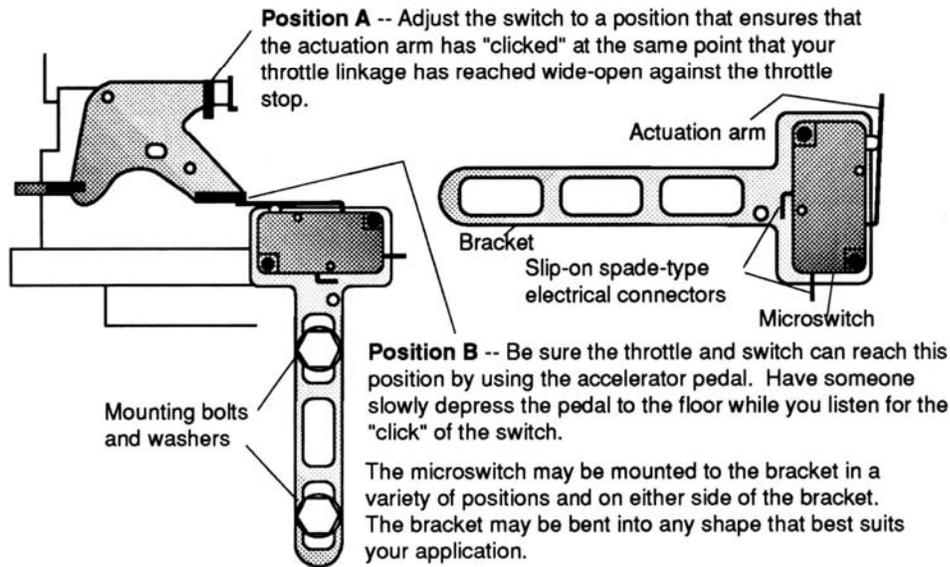

4. Connect the terminal on the controller marked "BAT" to the #2 terminal on your arming switch with the blue wire provided.
5. Connect the #1 terminal on the arming switch to the ignition switched +12V source.
6. Connect the #3 terminal on the arming switch to the ground.

NOTE: The current draw through this circuit is minimal (1-2 amps). NOS suggests that this terminal be connected to an ignition switched +12V circuit, to prevent the controller from being activated with the vehicle's ignition off.

7. Connect the terminal marked "SW" to the one terminal on the wide-open throttle microswitch, using the black 14 gauge wire.
8. Connect the remaining terminal on the wide-open throttle microswitch to the ground, using the black 14 gauge wire.
9. Connect the controller terminal marked "GND" to a good chassis ground using the orange 12 gauge wire.

NOTE: The entire current draw of the nitrous and fuel solenoid will pass through this terminal and wire. Be sure that you select an adequate ground or your system will not operate correctly.

10. Connect the terminal marked "NOS 2" to one wire from the redundant or safety solenoid, with the yellow wire provided.
11. Connect the terminal marked "NOS 1" to one wire from the nitrous solenoid, with the green wire provided.
12. Connect the terminal marked "GAS" to one wire from the fuel solenoid, with the red wire provided.

NOTE: Step 13A is for systems that DO NOT use a fuel pressure safety switch.

- 13A. Connect the remaining wires from the one fuel, one nitrous, and one redundant nitrous solenoids to a +12V source, using one fused orange wire provided.

NOTE: Repeat Step 13A for the remaining solenoids.

NOTE: When selecting a +12V source, keep in mind that the entire current draw from two nitrous solenoids and the two fuel solenoids approaches 30 amps. Connecting directly to the battery or some other circuit with high amp capability, such as a starter relay, is suggested.

NOTE: Steps 13B.1 and 13B.2 are for systems that employ a fuel pressure safety switch (One for each pair of nitrous and fuel solenoids).

- 13B.1 Connect the remaining wire from one pair of fuel and nitrous solenoids to one of the terminals on one of the fuel pressure safety switches. Repeat for the second pair of nitrous and fuel solenoids.
- 13B.2 Connect the open terminal on one fuel pressure safety switch and the open wire from one redundant nitrous solenoid to a +12V source, using one fused orange wire provided. Repeat for the other safety switch and redundant nitrous solenoid.

NOTE: When selecting a +12V source, keep in mind that the entire current draw from two nitrous solenoids and two fuel solenoids approaches 30 amps. Connecting directly to the battery or some other circuit with high amp capability, such as a starter relay, is suggested.

14. Install a 30 amp fuse in the fuse holder.

Figure 9 Wiring Diagram (Wet Manifold System with Two Nitrous and Two Fuel Solenoids)

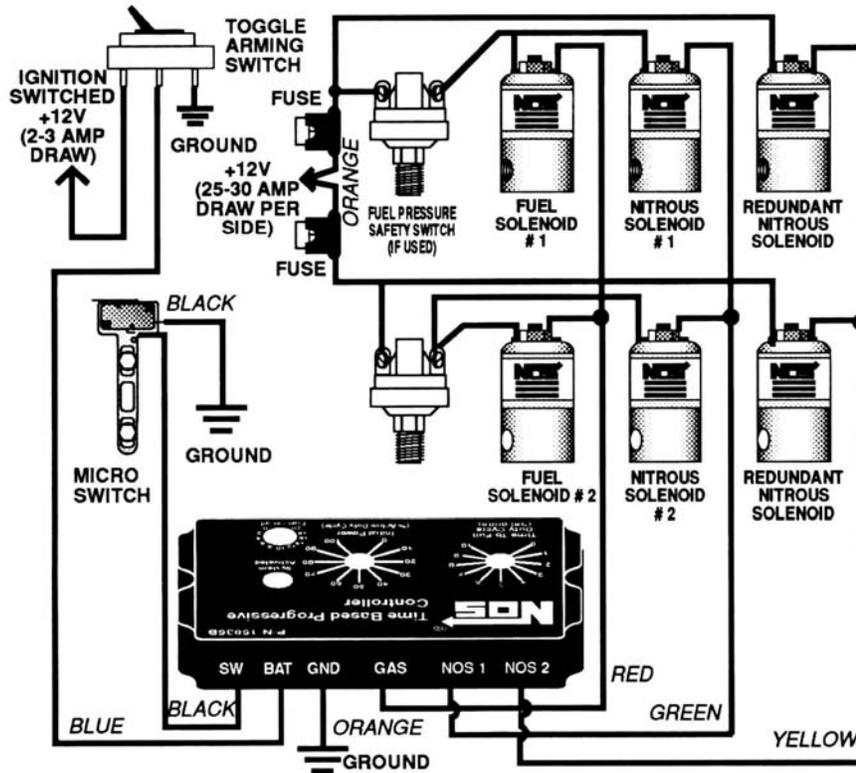

Chapter 3 Preparing for Operation

3.1 System Checkout

CAUTION! Before performing the following steps, ensure that the nitrous bottle valve is off and the nitrous feed line is empty. Failure to do so can result in an intake manifold explosion, causing serious injury or death.

NOTE: The timer function in the control module is reset whenever the arming switch is turned off. Failure to reset the timer will result in the system being at full power whenever the activation switch is triggered.

NOTE: The controller must be reset after any settings are changed.

1. Close the nitrous bottle valve if it is open. Purge the nitrous from the supply line.
2. Turn the vehicle ignition to "ON". Turn the arming switch to "ON".

NOTE: If the vehicle employs an electrical fuel pump, the pump should be shut off for Step 3.

3. Adjust the knobs on the control module as follows:
 - 1) Set the initial power at 20%
 - 2) Set the time to full power at 10 seconds.
4. Trigger and hold the activation switch for 10 seconds. The primary nitrous solenoid(s) and fuel solenoid(s) should start clicking, with the clicking frequency (tone) changing over 10 seconds. The clicking should stop after 10 seconds.

NOTE: If the solenoids do not appear to "cycle" correctly, refer to Appendix A, "Troubleshooting".

5. Turn the arming switch off and then on again.
6. Start the engine.
7. Open the nitrous bottle valve. There should be no change in the engine speed.
8. Check the nitrous lines and fittings for leaks.
9. ENJOY!!!

Chapter 4 Tuning Suggestions

4.1 Advanced Tuning Concepts

Initial power (solenoid duty cycle) is adjustable from 0-100%. The rate at which the solenoid duty cycle is increased (power increased) is adjustable from 0-10 seconds. The maximum power is adjusted through jetting changes, similar to a conventional nitrous oxide injection system.

This controller is configured to manipulate nitrous and fuel solenoids using the technique known as "pulse width modulation". Solenoids are opened, held open for a specific time (measured in milliseconds), and closed 35 times per second up until the time the 100% power setting is reached (equivalent to a solenoid duty cycle of .029 seconds or 29 milliseconds). At that time, the solenoids lock open until the system is de-energized. The amount of time the solenoids are held open is varied proportional to the settings (Initial Power and Time to Full Power) that you select using the controller knobs.

When using this controller with systems that feature nitrous and/or fuel jetting, whose total cross sectional area is significantly smaller than the orifice size of the nitrous or fuel solenoids, full power may be reached significantly quicker than the settings you have selected with the controller knobs.

Example "A":

Consider a nitrous system that features a nitrous solenoid with a .093" diameter orifice. If this solenoid is connected to 4 "Fogger" nozzles, each with a #20 (.020" diameter orifice) jet, you have the following scenario:

$$\text{Equivalent Jet Size} = \sqrt{(\text{Number of Jets} * (\text{Jet number} * \text{Jet Number}))}$$

In this case, 4 #20 jets are equivalent to a single #40 jet.

As you can see, the equivalent flow area of the #40 jet is less than half the flow area of the .093" orifice solenoid. When your solenoid reaches approximately 50% duty cycle, the valve will be flowing the maximum capability of the selected jetting, hence once you reach 50% duty cycle, you will have already attained the total power output of your system. In "seat of the pants" terms, your system will behave as if your controller settings are much more aggressive than your actual settings.

4.2 Adjusting Initial Power Increase and the Rate at which Additional Power is Applied

The use of this Nitrous Oxide Controller will allow you to tailor the application of power from your NOS nitrous oxide injection kit to maximize traction and minimize E.T. Changes in the starting line condition can easily be compensated for, with the turn of a knob.

NOTE: The controller must be reset after any settings are changed.

By applying as much power as your vehicle can handle at the starting line, you will be able to prevent excess wheel slippage. This is accomplished by adjusting the "Initial Power" knob to the point where maximum acceleration on launch is achieved, just prior to excess wheel slippage. The knob that adjusts the rate at which maximum power is attained can then be adjusted to bring power in as aggressively as traction limitations allow.

Figure 10 shows a pictorial representation of how power can be adjusted to fit your situation.

In the example shown, 20% power (solenoid duty cycle) is engaged when the system is activated. The solenoid duty cycle (percent "on" time) is increased linearly over the next 5 seconds until full power is reached.

Figure 10 Tuning Map—Power Output Versus Time

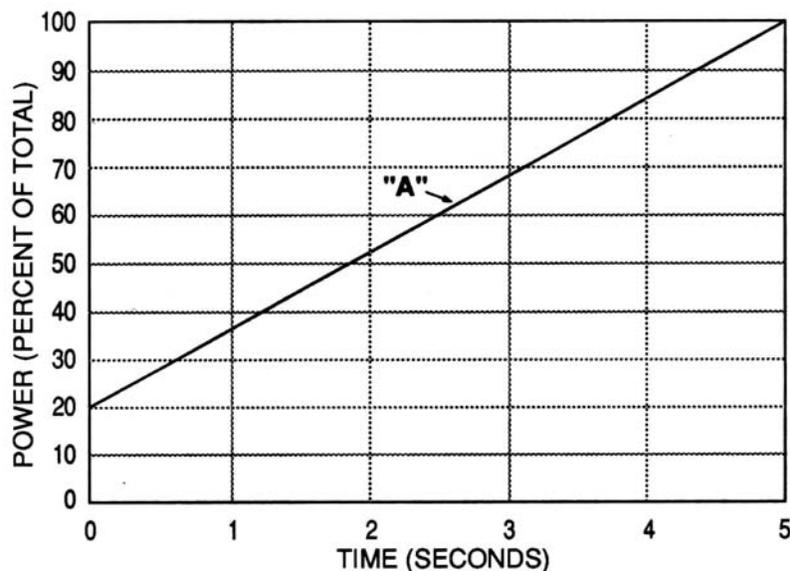

IMPORTANT TUNING TIP: Some high output wet manifold systems can encounter a stumble upon system initialization if a very low initial power setting is chosen and/or a low battery voltage situation is encountered. In these circumstances, setting the Fuel Solenoid Offset to something other than zero (always move in small increments, no more than 5% at a time) should move this stumble.

Chapter 5 Routine Maintenance

The cyclic operating nature of this system greatly reduces the life expectancy of the primary nitrous solenoid plunger. A worn or damaged plunger can cause leakage or improper metering of nitrous; the result of which may be engine damage or fire. For these reasons, it is important to routinely inspect the primary nitrous plunger seal every 6 minutes of operation (6 minutes of activated time). Follow the procedures listed below for solenoid inspection and maintenance. For additional solenoid information, see NOS Technical Bulletin #201.

5.1 Solenoid Inspection and Maintenance

1. Turn off the nitrous bottle valve.
2. Carefully relieve the pressure in the nitrous lines.

CAUTION! Inhalation of nitrous oxide can cause death. Contact of skin with nitrous oxide can cause severe frostbite.

3. Unscrew the retaining nut from the top of the solenoid. See Figures 11 and 12 for the solenoid exploded views.
4. Remove the solenoid coil.
5. Place the spanner nut over the solenoid stem and engage the drive dowels in the holes in the top of the stem. Remove the stem turning the spanner nut counterclockwise.

NOTE: Do not grip the stem. Damage to the stem will result.

6. Remove the plunger and the spring. Examine the seat for damage. Figure 13 shows a plunger in good working condition. If there are any cuts, or evidence of missing plunger material, discard the plunger, spring, and base seal. Replace the components with new NOS service parts. Table 3 lists the solenoid rebuilding kits for all popular NOS solenoids.
7. Repeat steps 3-6 in the reverse order.

Figure 11 Powershot/Super Powershot Solenoid Exploded View

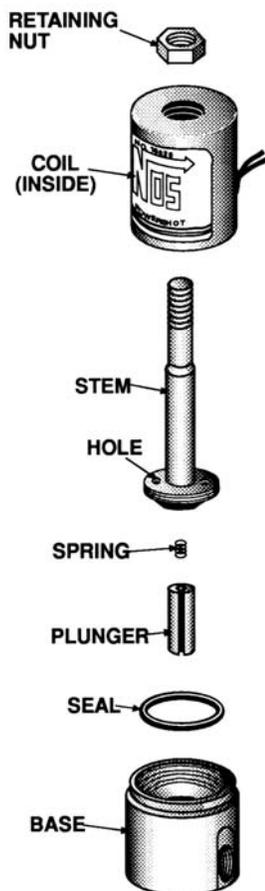

Figure 12 Cheater/Big Shot/Pro Shot Solenoid Exploded View

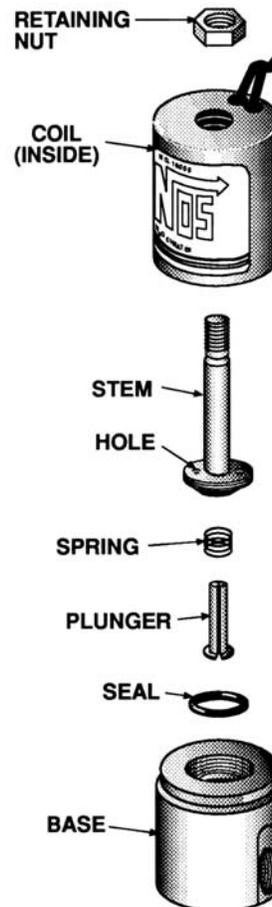
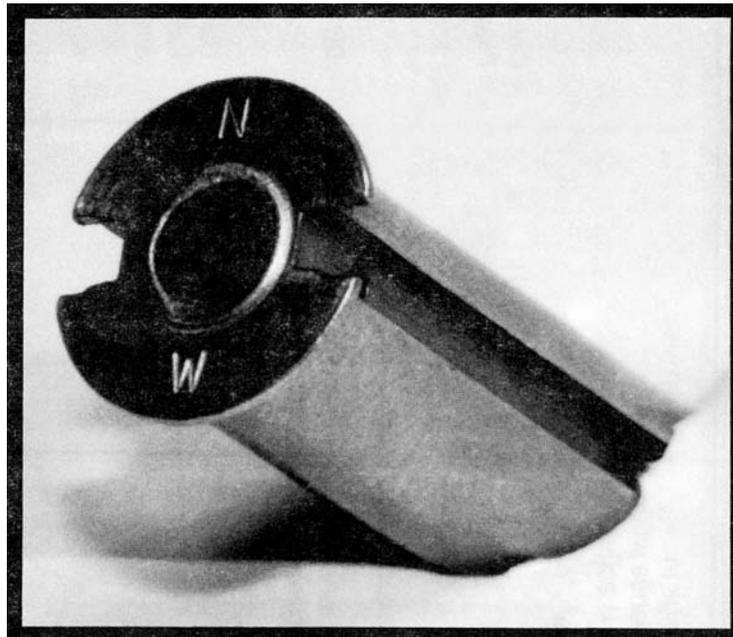

Table 3 Solenoid Rebuilding Kit Part Numbers

SOLENOID #	REQUIRES KIT #
16000NOS	16001NOS
06020NOS	16021NOS
16025NOS	16026NOS
16040NOS	16041NOS
16045NOS	16046NOS
16050NOS	16051NOS
16080NOS	16081NOS

Figure 13 Solenoid Seal



Normal wear should be flat except for small circular indentation.

Appendix A Troubleshooting Guide

The troubleshooting chart on the following pages should help determine and rectify most problems with your installed NOS system. If you still need assistance determining or fixing problems, call the NOS Technical Support at 1-866-GOHOLLEY.

PROBLEM	POSSIBLE CAUSES	DIAGNOSTIC PROCEDURE	CORRECTIVE ACTION
No change in performance when system is activated.	Blown fuse.	-----	Replace.
	System wired incorrectly.	Compare to wiring diagram, Figures 5, 7, or 9.	Repair, if necessary.
System runs rich when activated.	Failed plunger in primary nitrous solenoid.	Disassemble and inspect.	Replace.
	Malfunctioning safety solenoid.	Disconnect primary nitrous and fuel solenoid wires. Arm and activate the nitrous system. A loud click should be heard from the safety solenoid.	Replace the safety solenoid.
	Malfunctioning control module.	Disconnect primary nitrous and fuel solenoid wires. Arm and activate nitrous system. Check for 12V at safety solenoid wire.	Replace control module.

NOS Technical Support
Phone: 1-866-GOHOLLEY
Fax: 1-270-781-9772

For online help, please check the Tech Service section on our website: www.holley.com

A5074-SNOS
Date: 04-23-01