

MICRO STORM

2-Stage, Dual Ramp Progressive Nitrous Controller

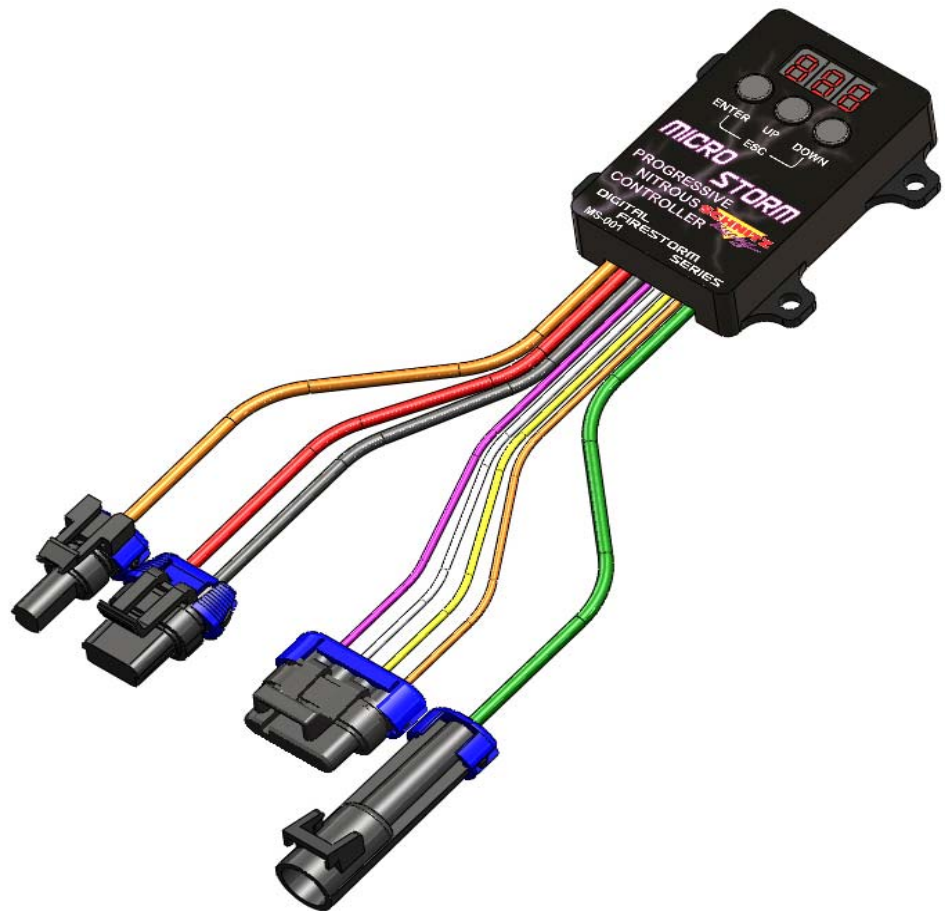

www.seellc@mchsi.com

Info@schnitzracing.com

Product description—The Micro Storm progressive nitrous controller provides control for two stages of nitrous with a maximum of five setups (user can choose one of five setups). Each stage has independent control parameters (optional dual ramp feature can be turned ON by user) and are controlled by a single activation input. A Clutch/Trans Brake input is provided for launch control. When the Clutch/Trans Brake input is active (+12 volt applied) the nitrous activation is ignored until the Clutch/Trans Brake input is released. This eliminates the need for additional relays when staging at wide open throttle.

The activation input can be configured for +12 volt activation or TPS (throttle position sensor) activation. When a TPS is used the closed throttle voltage and WOT (wide open throttle) are user programmable with either manual adjustment or using Live sensor readings. The TPS input works with either a rising or falling signal, the only requirement is that the signal must span a minimum of 2.5 volts. If the entered values for closed and WOT throttle voltages are less than 2.5 volt span an error code will be displayed until corrected and the unit will be disabled.

There is an integrated RPM window switch function with a wide range of tach signal input frequencies available. This feature is disabled if NO tach input signal is present.

Please see parameter section for more operational information and how to program the unit.

Important Information - When using a conventional style ignition coil (Not Coil on Plug) you must use Static Suppression Ignition Wires with this Controller.

Caution - Do NOT submerge Controller in liquid or directly wash unit with liquid of any type! (Do NOT spray when washing vehicle!)

It is the responsibility of the purchaser to follow all guidelines and safety procedures supplied with this product and any other manufactures product used with this product. It is also the responsibility of the purchaser to determine compatibility of this device with the vehicle and other components.

Shutt Electronics & Engineering LLC assumes no responsibility for damages resulting from accident, improper installation, misuse, abuse, improper operation, lack of reasonable care, or all previously stated reasons due to incompatibility with other manufacturer's products.

Shutt Electronics & Engineering LLC assumes no responsibility or liability for damages incurred from the use of products manufactured or sold by Shutt Electronics & Engineering LLC on vehicles used for competition racing. Shutt Electronics & Engineering LLC neither recommends nor approves the use of products manufactured or sold by Shutt Electronics & Engineering LLC on vehicles which may be driven on public highways or roads, and assumes no responsibility for damages incurred from such use.

It is the purchaser's responsibility to check the state and local laws pertaining to the use of Nitrous Oxide for racing applications. Shutt Electronics & Engineering LLC does not recommend nor condone the use of its products for illegal street racing.

Warranty

Shutt Electronics & Engineering LLC warrants to the original purchaser that the controller shall be free from defects in parts and workmanship under normal use for 180 days from the date of purchase.

Shutt Electronics & Engineering LLC obligation under this warranty is limited to the repair or replacement of any component found to be defective when returned postpaid to Shutt Electronics & Engineering LLC . The Controller must be returned with evidence of place and date of purchase or warranty will be void. The warranty will not apply if the controller has been installed incorrectly, repaired, damaged, or tampered with by misuse, negligence or accident.



Programming button description.

ENTER—Accept and enter programming mode.

UP—Increment value up or change selection.

DOWN—Decrement value down or change selection.

ESC—Press “ENTER” + “DOWN” for ESC key.

COMBO—Press “UP” + “DOWN” for COMBO key.

Parameter list, (G) = global, (C) = current setup.

- | | |
|---|--|
| 1—(G) Current active setup, 5 available | 18—(G) Stage2 solenoid pulse frequency, 10 to 40 hZ |
| 2—(C) Nitrous delay time, Stage1 | 19—(G) Tach signal input frequency |
| 3—(C) Nitrous start percent, Stage1 | 20—(G) Nitrous ON rpm |
| 4—(C) Nitrous final percent1, Stage1 | 21—(G) Nitrous OFF rpm |
| 5—(C) Nitrous build time1, Stage1 | 22—(G) Timer/Shift Light Output Select
(Timer = 0, Shift Light = 1) |
| 6—(C) Nitrous delay time, Stage2 | 23—(G) Timer delay or Shift RPM |
| 7—(C) Nitrous start percent, Stage2 | 24—(G) Turn dual ramp option ON/OFF
(OFF = 0, ON = 1) |
| 8—(C) Nitrous final percent1, Stage2 | |
| 9—(C) Nitrous build time2, Stage2 | |
| 10—(G) Resume mode, Hold & Wait or Reset
(Reset = 0, Hold & Wait = 1) | |
| 11—(G) Main timer period, 20 to 300 seconds | |
| 12—(G) TPS enable, use TPS signal for activation
(Disable = 0, Enable = 1) | |
| 13—(G) TPS closed throttle volts, manual adjust | |
| 14—(G) TPS wide open throttle volts, manual adjust | |
| 15—(G) TPS percentage for activation, 70% to 100% | |
| 16—(G) Set TPS closed & WOT voltage with Live data | |
| 17—(G) Stage1 solenoid pulse frequency, 10 to 40 hZ | |

Dual ramp optional parameters

- | |
|---------------------------------------|
| 25—(C) Nitrous final percent2, Stage1 |
| 26—(C) Nitrous build time2, Stage1 |
| 27—(C) Nitrous final percent2, Stage2 |
| 28—(C) Nitrous build time2, Stage2 |

“Global” parameters are settings that are applied no matter which setup is selected.

“Current” setup parameters are settings that control the individual nitrous stages. Such as delay, start percent, final percent, etc... There are five setups available, this allows the user to change between pre-programmed nitrous setups easily. Parameter #1 controls which setup is selected (currently active).

Ready mode, the controller must be in Ready mode to be activated. This is the default mode when the unit is powered up. The display will read “r 1” if the current setup is #1. “r 2” for setup #2, etc...

The “Current Setup” can be changed from the ready screen by pressing and holding either the “UP” or “DOWN” button for 2.5 seconds.

To return all of the settings to factory default press and hold the “ESC” buttons for 20 seconds while in ready mode

Programming mode, to enter programming mode the controller must be in the ready state. The display will read “r 1” if the current setup is #1. “r 2” for setup #2, etc... To get to the ready screen press the “ESC” buttons or this is the default screen when the unit is powered up.

From the ready screen press and hold the “ENTER” button for 2.5 seconds. When the display reads “PPP” release the button. The first parameter will now be selected and the display will read “P. 1”, use the “UP”, “DOWN” buttons to scroll through all of the parameters. The parameter count will roll over if the minimum or maximum selection is exceeded. This allows for quick access to the optional Dual Ramp parameters if they are turned ON.

Once the desired parameter has been selected press and hold the “ENTER” button for 1 second. When the display reads “PPP” release the button. Use the “UP”, “DOWN” buttons to adjust the setting. The new setting is automatically saved as it adjusted. Press and hold the “UP”, “DOWN” buttons for accelerated adjust rate. Press the “ENTER” button to return to the parameter selection menu.

Continue selecting and adjusting any parameters that need to be set. You can exit the programming mode at any time by pressing the “ESC” buttons. Note—you do NOT have to go through all of the settings.

Live Data mode, to enter live data mode the controller must be in the ready state. The display will read “r 1” if the current setup is #1. “r 2” for setup #2, etc... To get to the ready screen press the “ESC” buttons or this is the default screen when the unit is powered up.

From the ready screen press and hold both the “UP” & “DOWN” (COMBO) buttons for 2.5 seconds. When the display reads “0.00” release the buttons. The display will now show the signal voltage applied to the Activation/TPS input. If a voltage greater than 5.00 volts is applied the display will read a maximum of 5.00 volts. No damage will be done if a +12 volt signal is applied to this input.

Press the “DOWN” button to display engine RPM and the “UP” button to return to activation input voltage. Press “ESC” buttons to exit to the ready screen.

Press the “ESC” buttons to return to the ready screen/mode.

Please read page 4 “Programming mode” for instructions on how to adjust individual parameters.

1—Current Setup, this setting controls which setup is active. Valid range is 1 to 5 in increments of 1.

Stage1 settings

2—Nitrous Delay Time Stage1, this setting controls the delay time in seconds for nitrous stage1. Valid range is 0.00 to 9.99 in increments of .01 second.

3—Nitrous Start Percent Stage1, this setting controls the start percentage for nitrous stage1. If there is a delay value programmed for stage1 the start percentage will not be applied until the delay timer has expired. Use this value to control the initial nitrous power applied. Valid range is 10% to 100% in 1% increments.

4—Nitrous Final Percent1—Stage1, this setting controls the final or maximum nitrous power applied if the “Dual Ramp” feature is OFF. The nitrous power ramp will be the start percentage to the final percentage and the ramp time is controlled by the build time setting. The start percent can be lower than the final percent allowing for power to be taken away over time if desired. Valid range is 10% to 100% in 1% increments.

5—Nitrous Build Time1—Stage1, this setting controls the time it takes stage1 to go from the starting percentage to the final percentage. The nitrous will progressively ramp from the start to final setting in the time programmed for this parameter. A shorter time (example 0.2 second) will create a very aggressive ramp and a longer time (example 9.9 seconds) will create a smoother application of power. Valid range is 0.0 second to 9.9 seconds in .1 second increments.

Stage2 settings

6—Nitrous Delay Time Stage2, this setting controls the delay time in seconds for nitrous stage2. Valid range is 0.00 to 9.99 in increments of .01 second.

7—Nitrous Start Percent Stage2, this setting controls the start percentage for nitrous stage2. If there is a delay value programmed for stage2 the start percentage will not be applied until the delay timer has expired. Use this value to control the initial nitrous power applied. Valid range is 10% to 100% in 1% increments.

8—Nitrous Final Percent1—Stage2, this setting controls the final or maximum nitrous power applied if the “Dual Ramp” feature is OFF. The nitrous power ramp will be the start percentage to the final percentage and the ramp time is controlled by the build time setting. The start percent can be lower than the final percent allowing for power to be taken away over time if desired. Valid range is 10% to 100% in 1% increments.

9—Nitrous Build Time1—Stage2, this setting controls the time it takes stage2 to go from the starting percentage to the final percentage. The nitrous will progressively ramp from the start to final setting in the time programmed for this parameter. A shorter time (example 0.2 second) will create a very aggressive ramp and a longer time (example 9.9 seconds) will create a smoother application of power. Valid range is 0.0 second to 9.9 seconds in .1 second increments.

Please read page 4 “Programming mode” for instructions on how to adjust individual parameters.

10—Resume Mode—Hold & Wait or Reset, This setting allows the Progressive system to Hold & Wait when the Activation signal is removed. Example - the throttle is lifted due to wheel spin or ? This allows the Progressive system to resume at the point where the throttle was lifted. If this option is OFF the Progressive system and All Timers will reset each time the Activation is removed.

0 = Hold & Wait is OFF, Reset mode.

1 = Hold & Wait is ON.

11—Main timer period, 20 to 300 seconds, this controls the total time elapsed before a System Timeout occurs. This limits the total amount of time the solenoids can be On if the Activation signal is never removed. This setting also allows the system to be used with Wait & Hold option and the Progressive Timers will reset after the Timeout Period has elapsed and the Activation signal is removed. If a reset is needed before the timer has elapsed turn the controller off and back on. This method is by design to prevent the unit from being inadvertently reset during operation. Valid range is 20 to 300 seconds in 1 second increments.

12—TPS enable, use TPS signal for activation, this setting determines the activation input function. The activation input can be configured for +12 volt activation or to read a TPS (throttle position sensor) signal. When configured for +12 volt activation any voltage above 4.00 volts will be accepted as ON. When configured for TPS signal the closed throttle voltage and WOT (wide open throttle) voltage will need to be programmed for proper operation. A voltage span of at least 2.50 volts between closed and WOT throttle position is required. An error code will be displayed on the “Ready” screen if this condition is not met.

0 = TPS enable OFF, +12 volt activation mode.

1 = TPS enable ON, must configure for proper operation.

13—TPS closed throttle volts—manual adjust, this setting is only used if TPS enable option is ON. The value of this setting should be the closed throttle position voltage. See parameter #16 to configure using live TPS data. Valid range is 0.00 to 5.00 volts in .01 volt increments.

14—TPS wide open throttle volts—manual adjust, this setting is only used if TPS enable option is ON. The value of this setting should be the WOT (wide open throttle) throttle position voltage. See parameter #16 to configure using live TPS data. Valid range is 0.00 to 5.00 volts in .01 volt increments.

15—TPS percentage for activation, this setting is only used if TPS enable option is ON. This setting determines the TPS percent at which system activation will occur. Valid Range is 70 to 100 percent in 1 percent increments.

16—Set TPS closed & WOT voltage with Live data, this setting is only used if TPS enable option is ON. When using this feature enter programming mode as outlined on page 4. The display will show the TPS voltage, make sure the throttle is in the closed position and press “ENTER”. Next open the throttle to maximum position (on drive by wire cars this may require additional help to obtain true open position.) and press “ENTER”. These values can be manually adjusted if need using parameters 13 and 14. There must be a minimum voltage span of 2.50 volts between closed and WOT settings. The voltage can sweep up or down as long as there is a span of at least 2.50 volts.

Important—if the voltage span between closed throttle and wide open throttle settings is less than 2.50 volts an error code will be set. This code will be displayed on the ready screen as “er1”. To correct this error program the TPS parameters again and insure a span of at least 2.50 volts.

Please read page 4 “Programming mode” for instructions on how to adjust individual parameters.

17—Stage1 solenoid pulse frequency, this setting determines the stage1 solenoid operating frequency in hertz. Typical setting is from 15 to 25 hertz. There are many different solenoid designs and individual testing is the only way to determine what is the best setting for a given setup. Valid range is 10 to 40 hertz in 1 hertz increments.

18—Stage2 solenoid pulse frequency, this setting determines the stage1 solenoid operating frequency in hertz. Typical setting is from 15 to 25 hertz. There are many different solenoid designs and individual testing is the only way to determine what is the best setting for a given setup. Valid range is 10 to 40 hertz in 1 hertz increments.

19—Tach signal input frequency, this setting determines the number of tach signal input pulses per revolution of the crankshaft. If this setting is in-correct the RPM reading will not correspond to actual engine speed.

0 = 1 pulse per 2 revolutions (Coil on Plug applications).

1 = 1 pulse per revolution.

2 = 1.5 pulse per revolution (3-cylinder applications).

3 = 2 pulse per revolution.

4 = 2.5 pulse per revolution (5-cylinder applications).

5 = 3 pulse per revolution.

6 = 4 pulse per revolution.

7 = 5 pulse per revolution.

20—Nitrous ON rpm, this is the minimum RPM required for nitrous activation. If there is no tach input signal this feature is disabled. This setting MUST be lower than the Nitrous Off RPM. Valid range is 0 to 16,000 RPM in 100 RPM increments.

21—Nitrous OFF rpm, this is the minimum RPM required for nitrous activation. If there is no tach input signal this feature is disabled. This setting MUST be greater than the Nitrous On RPM. Valid range is 0 to 16,000 RPM in 100 RPM increments.

22—Timer / Shift Light Select, this setting determines if the Relay Output functions as a Timer with Delay or a RPM controlled Shift Light Output. 0 = Timer function, 1 = Shift Light function.

23—Timer function selected, Delay in seconds before the output turns on. Valid range is 0.00 to 9.99 in .01 second increments. Timer starts when controller is “Activated”.

Shift Light function selected, RPM that output will turn on. Valid Range is 0 to 16,000 RPM in 100 RPM increments.

Please read page 4 “Programming mode” for instructions on how to adjust individual parameters.

24—Turn dual ramp option ON/OFF, this setting can be used to enable a dual ramp feature. When the dual ramp feature is ON there is a second final percentage and a second build time for each stage of nitrous. This feature can be used to limit nitrous power during launch and then use the second ramp to aggressively apply power once the vehicle is moving and weight transfer has occurred. Example—Start% = 20, Final% 1 = 35, Build Time1 = 2.5 seconds, Final% 2 = 100, Build Time2 = 1 second.

0 = Dual ramp option off.

1 = Dual ramp option on.

Dual ramp optional parameters

25—Nitrous Final Percent2—Stage1, this setting controls the final or maximum nitrous power applied if the “Dual Ramp” feature is ON. The nitrous power ramp will be the start percentage to final percent #1, final percent #1 to final percent #2. The ramp time is controlled by the build time #1 and build time #2 settings. The progressive ramps can be programmed to increase or decrease the nitrous power. Valid range is 10% to 100% in 1% increments.

26—Nitrous Build Time2—Stage1, this setting controls the time it takes stage1 to go from final percent #1 to the final percent #2. A shorter time (example 0.2 second) will create a very aggressive ramp and a longer time (example 9.9 seconds) will create a smoother application of power. Valid range is 0.0 second to 9.9 seconds in .1 second increments.

27—Nitrous Final Percent2—Stage2, this setting controls the final or maximum nitrous power applied if the “Dual Ramp” feature is ON. The nitrous power ramp will be the start percentage to final percent #1, final percent #1 to final percent #2. The ramp time is controlled by the build time #1 and build time #2 settings. The progressive ramps can be programmed to increase or decrease the nitrous power. Valid range is 10% to 100% in 1% increments.

28—Nitrous Build Time2—Stage2, this setting controls the time it takes stage2 to go from final percent #1 to the final percent #2. A shorter time (example 0.2 second) will create a very aggressive ramp and a longer time (example 9.9 seconds) will create a smoother application of power. Valid range is 0.0 second to 9.9 seconds in .1 second increments.



If connecting to a TPS signal for activation the controller MUST be configured properly (see parameter #12) and the controller MUST be turned on even if the nitrous system is NOT activated.

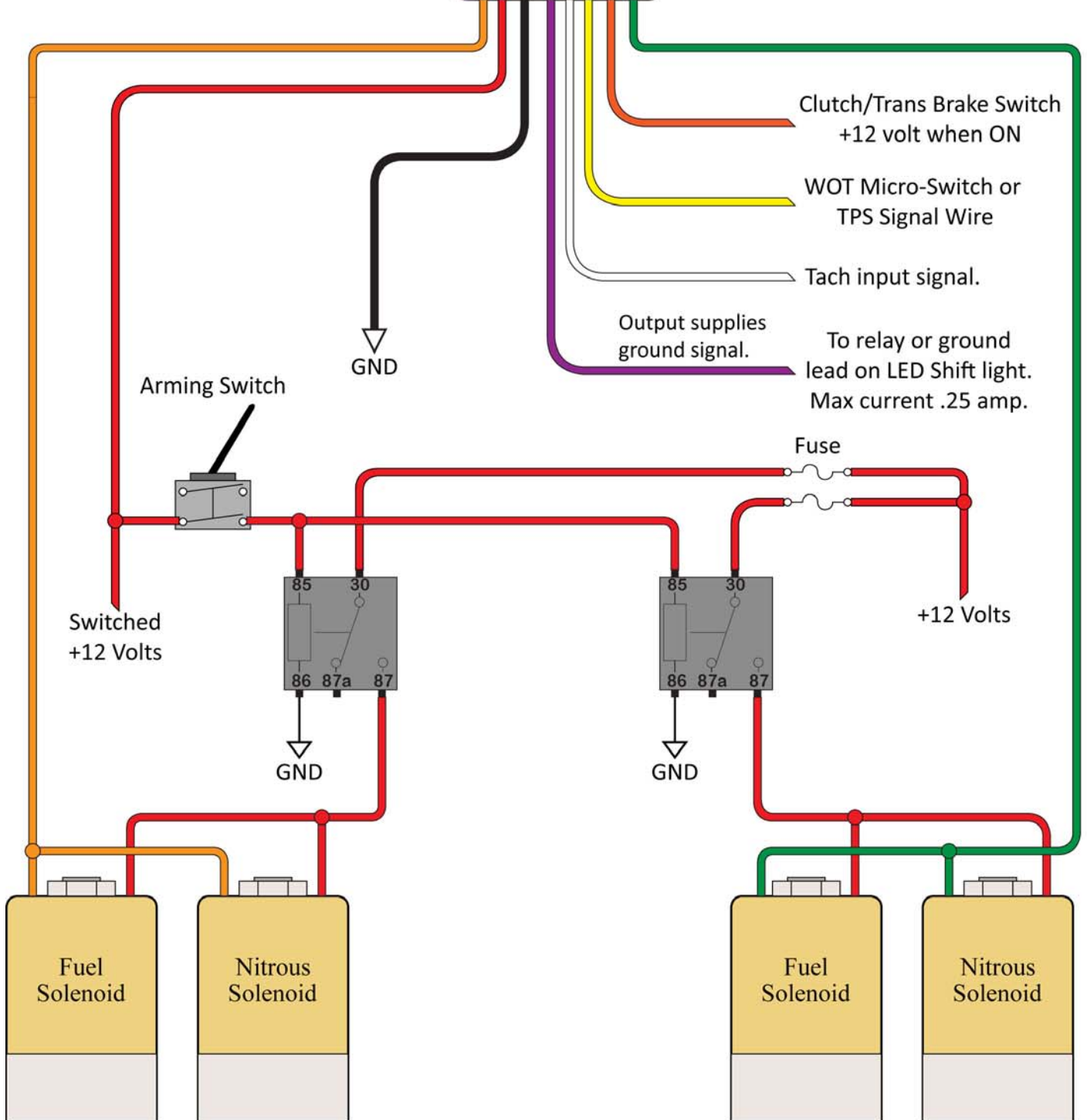

Important Information...

Battery Ground, the best place to connect the Black, 16 ga wire is directly to the battery negative terminal. If this is NOT possible then the connection should be to the frame. There MUST be a quality, large diameter ground cable going from the battery negative terminal to the frame if the frame connection method is used.

TPS Signal Connection, the installer must determine the proper wire to obtain the throttle position signal. If a wiring diagram is not available a volt meter can be used to locate the proper wire.

1—locate the throttle position sensor wires.

2—connect the negative lead of the voltmeter to a good ground.

3—with key on probe the wires with the voltmeter, there should be a signal ground (will read 0.0 or close to 0.0 volts), a signal reference voltage (typically 4.90 to 5.00 volts), and the signal wire. The voltage on the signal wire will sweep when the throttle is moved. The wire with the changing voltage is the signal wire. The voltage may be rising or falling.

4—insure that there is a voltage change of at least 2.50 volts when moving the throttle from the closed position to wide open position. If there is not at least a 2.50 volt span then the TPS signal cannot be used to trigger the activation input.

5—you can record the closed and wide open throttle voltages to manually enter into the setup parameters or use Live Data mode as outlined in the programming instructions.

Important—if the voltage span between closed throttle and wide open throttle settings is less than 2.50 volts an error code will be set. This code will be displayed on the ready screen as “er1”. To correct this error program the TPS parameters again and insure a span of at least 2.50 volts.

Tach (RPM) Input Signal, the tach input signal can be connected to the coil negative terminal or a dedicated square wave signal from the ECM or other source.

Some ECM applications do NOT have a dedicated tach signal by default and may be turned ON using aftermarket programming solutions. These ECM's do NOT provide a pull-up resistor internally and a 4.7 k-ohm, 1/4 watt resistor will need to be connected from +12V to the tach signal wire.