

MPS Fast FI Mixture Control Installation Instructions



The MPS Fast FI Mixture Control P/N 1-0337 is a simple means to adjust the fuel curves on your fuel-injected motorcycle. This allows for tuning after the installation of aftermarket exhausts, intake modifications, or internal motor modifications. It can only richen the fuel mixture. It cannot lean the mixture. The Fast FI Mixture Control has a low speed pot that adds fuel at low speed much like a mixture screw on a carburetor. The

accelerator pump pot is a extra enrichment when the unit senses rapid rpm acceleration. This acts like the traditional accelerator pump on a carburetor. The high-speed pot controls the high RPM like the main jet of a carburetor. The high-speed RPM set pot determines what RPM the low speed pot is no longer controlling the mixture and the high-speed pot takes over. The Fast FI Mixture Control has an instant rich feature to work with Dry Nitrous Systems. It locks the fuel injection system in a full rich mode instantly via a signal from the Dry Nitrous System. This means no more reprogramming for NOS operation. The Fast FI Mixture Control was designed to be a universal application and will work on most late model four cylinder electronic fuel injected motorcycles. The Fast FI Mixture Control looks at the fuel injection map the same way the factory does and adjusts it the same way the factory does. Because our product is not compatible with other aftermarket products we recommend removing any other type of non-factory adjustments, downloads, etc. before installing the Fast FI Mixture Control.

Mounting – The Fast FI Mixture Control should be mounted as accessible as possible. Choose a spot that all the wires will reach their proper connections. Use the Velcro to mount the box to a secure spot.

Electrical – The Fast FI Mixture Control has only 7 electrical connections. The red wire is the power lead and should be connected to a ignition switched 12 volt power source. The black wire is the ground and should be connected to a good ground preferably at the battery. The red with yellow tracer

wire is the instant rich activation lead and should be tapped into the positive nitrous solenoid wire.

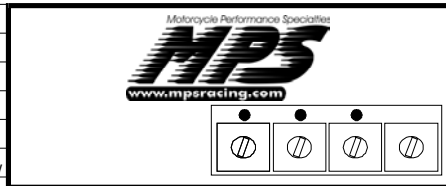
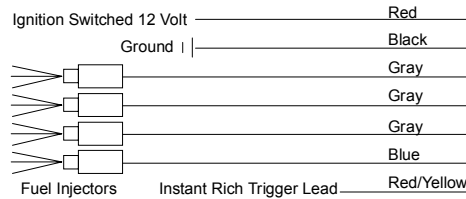

Applying 12 volts to this wire will activate the instant rich mode of the Fast FI Mixture Control. The one blue wire and the three gray wires are tapped into injector signal wire of each cylinder. It doesn't matter which cylinder the blue wire goes to. There will be two wires on each injector. Each injector should have one common colored wire for each cylinder. The common color wires are not the signal wire. **The signal wire will be the unique colored wire on each injector.** Using the wire tap connectors provided carefully tap into the four trigger wires

Phone: 407.330.9727 – Fax: 407.322.8632
5350 McIntosh Point #132 – Sanford, Florida 32773

at the ECU after verifying the proper color at the injector. Take time to be sure these connectors are properly installed.

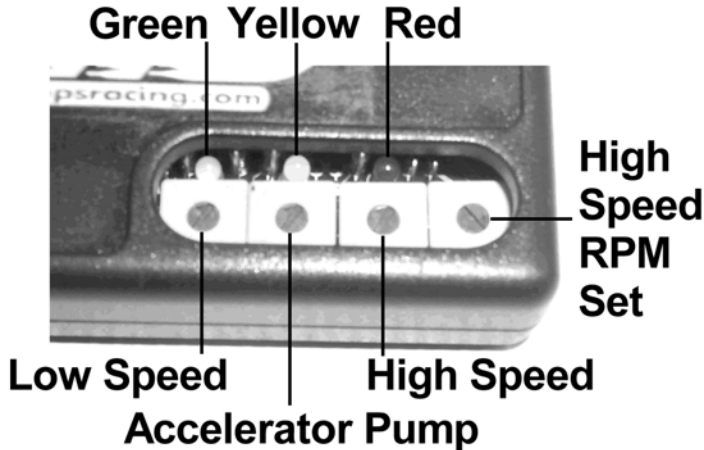

Testing – Remove the plug that covers the four adjustment pots and the three LEDs. Turn on the ignition switch. The green LED should flash. If the green LED does not flash when the key is turned on either the red or the black wire is not wired correctly. When the bike is started and idling the green LED should be steady green. The unit has self-diagnosing features that will help you troubleshoot your installation. If the green light is flashing with the bike running at idle the blue wire is either not on the signal wire to the injector or has a poor connection. Correct this and restart the bike. If you see the red light flashing this indicates a

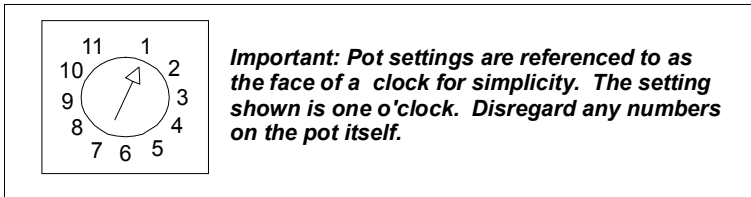

improper gray wire connection. The red light diagnosis will not work with the green light flashing. You must correct the blue wire connection first. You will also notice a flashing yellow at start up. This is normal and should end in 5 – 20 seconds. If the red light is on steady at startup, the high-speed rpm pot is adjusted to low. Set the high-speed rpm pot to 9000 rpm and verify that the red light has gone out and the green light is on steady. Set the high speed rpm pot to 6000 rpm as a starting point and rev the engine quickly above that. Notice that the lights go green to red at the set point. **Note: All light tests with the bike running are performed at idle. Any of the lights can and will flash on acceleration and deceleration. This is the normal condition.**

Tuning – The Fast FI Mixture Control has several pots used to control fuel mixture at different points in the power curve. All operations are performed with the bike at operating temperature.

Low Speed Fuel Pot – The low speed fuel pot functions like a carburetor mixture screw controlling fuel mixture at low rpm and light throttle operation. The low speed pot settings are all referenced to the face of a clock for simplicity. Disregard any numbers on the pot itself. **The pots do not rotate all the way around. They go from one o'clock to the eleven o'clock position and stop. Do not rotate all the way around because they will break and are not covered under any warranty.** One o'clock is the stock factory setting and will not change the fuel delivery. This should be your starting point for all adjustments.

Adjusting the low speed pot: Put the bike in neutral and rev it to a fast idle speed approx 2000 to 3000 rpm and hold the rpm steady. You may be able to set the idle up with the idle screw. Slowly turn the low speed pot adjustment clockwise to richen the fuel mixture while listening to the exhaust note. You should adjust richer until you hear the motor smooth out and/or attain maximum rpm.

Accelerator Pump Pot – The accelerator pump pot functions like a carburetor accelerator pump. The accelerator pump pot adds fuel to the low speed pot when the throttle is opened rapidly. The

accelerator pump pot settings are all referenced to the face of a clock for simplicity. Disregard any numbers on the pot itself. **The pots do not rotate all the way around. They go from one o'clock to the eleven o'clock position and stop. Do not rotate all the way around because they will break and are not covered under any warranty.** One o'clock is the stock factory setting and will not change the fuel delivery. This should be your starting point for all adjustments. Generally, the same setting that you have on the low speed pot will be a good starting point on the accelerator pump pot.

RPM Switch Pot – The rpm switch pot is used to tell the unit to switch from the low speed and accelerator pump pots to the high speed pot. The rpm switch pot settings are all referenced to the face of a clock for simplicity. One o'clock is 1000 rpm, two o'clock is 2000 rpm, and so on. Disregard any numbers on the pot itself. **The pots do not rotate all the way around. They go from one o'clock to the eleven o'clock position and stop. Do not rotate all the way around because they will break and are not covered under any warranty.** Set the rpm switch pot at around ½ the red line of the bike as a starting point.

High Speed Fuel Pot – The high speed fuel pot functions like a carburetor main jet controlling fuel mixture at high rpm and full throttle operation. The high speed pot settings are all referenced to the face of a clock for simplicity. Disregard any numbers on the pot itself. **The pots do not rotate all the way around. They go from one o'clock to the eleven o'clock position and stop. Do not rotate all the way around because they will break and are not covered under any warranty.** One o'clock is the stock factory setting and will not change the fuel delivery. This should be your starting point for all adjustments.

Adjusting the High Speed Pot: Turning the high speed pot adjustment clockwise richens the fuel mixture. Most bikes will remain at the stock settings unless aftermarket pipes, intake modifications, or engine modifications have been performed. We recommend a dyno pull or two to set the high speed pot.

Instant Rich Feature – The instant rich feature locks the injectors in a full rich mode. The MPS Fast FI Mixture Control delivers as much fuel as the factory injectors and ECU can deliver. This feature should be used only with a dry nitrous system. The wiring diagram for the MPS Dry Nitrous System used with the MPS Fast FI Mixture Control is below.

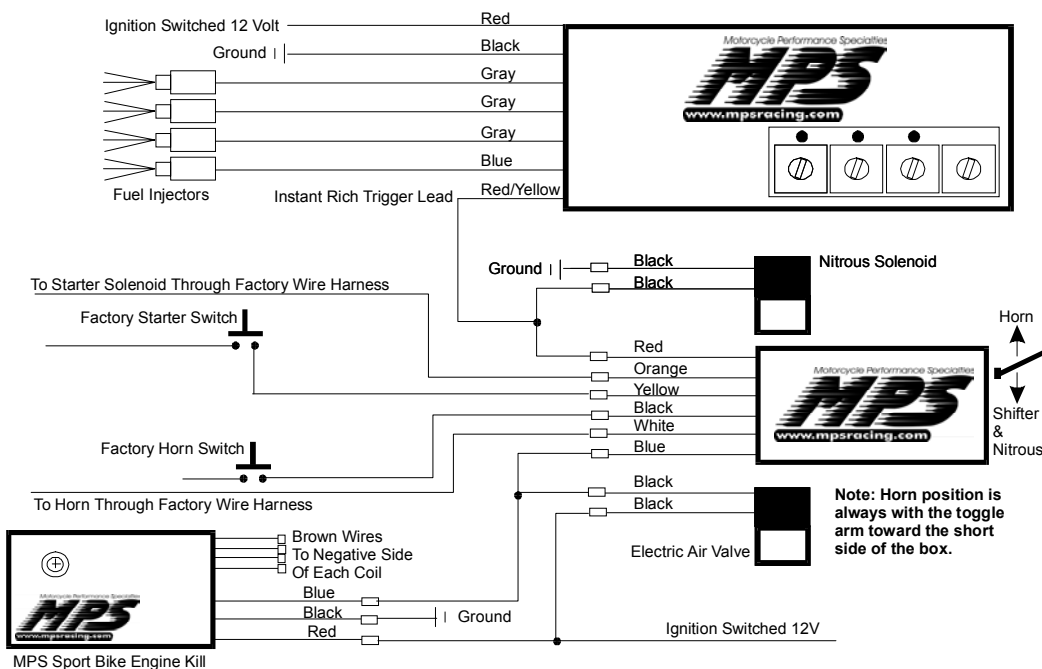

Phone: 407.330.9727 – Fax: 407.322.8632
5350 McIntosh Point #132 – Sanford, Florida 32773

Injector And Ignition Switched Power Wire Colors & Starting Point Settings For Slip On Exhausts

Honda 98-03 VFR800

Injector Wire Colors

Injector Wires: Pink/Green – Pink/Yellow – Pink/Black – Pink/Blue

Ignition Switched Power Wire: Brown/White from taillight

Typical Settings

Low Speed Pot Setting: 2.5

Accelerator Pump Pot: 1.5

High Speed Pot: 1.0

High Speed RPM Set: 4500

Honda 98-03 VFR800 With O2 Sensor

Injector Wire Colors

Injector Wires: Pink/Green – Pink/Yellow – Pink/Black – Pink/Blue

Ignition Switched Power Wire: Brown/White from taillight

Typical Settings

Low Speed Pot Setting: 1.0

Accelerator Pump Pot: 3.0

High Speed Pot: 1.0

High Speed RPM Set: 5000

Honda 02-03 CB900F

Injector Wire Colors

Injector Wires: Pink/Green – Pink/Yellow – Pink/Black – Pink/Blue

Ignition Switched Power Wire: Brown/White from taillight

Typical Settings

Low Speed Pot Setting: 3.0

Accelerator Pump Pot: 3.0

High Speed Pot: 2.0

High Speed RPM Set: 4500

Honda 00-01 CB929RR

Injector Wire Colors

Injector Wires: Pink/Green – Pink/Yellow – Pink/Black – Pink/Blue

Ignition Switched Power Wire: Brown/White from taillight

Typical Settings

Low Speed Pot Setting: 3.0

Accelerator Pump Pot: 3.0

High Speed Pot: 2.0

High Speed RPM Set: 4500

Honda 00-01 CB929RR With O2 Sensor

Injector Wire Colors

Injector Wires: Pink/Green – Pink/Yellow – Pink/Black – Pink/Blue

Ignition Switched Power Wire: Brown/White from taillight

Typical Settings

Low Speed Pot Setting: 1.0

Accelerator Pump Pot: 3.5

High Speed Pot: 2.0

High Speed RPM Set: 5000

Honda 02-03 CB954RR

Injector Wire Colors

Injector Wires: Pink/Green – Pink/Yellow – Pink/Black – Pink/Blue

Ignition Switched Power Wire: Brown/White from taillight

Typical Settings

Low Speed Pot Setting: 3.0

Accelerator Pump Pot: 3.0

High Speed Pot: 2.0

High Speed RPM Set: 4500

Honda 02-03 CB954RR With O2 Sensor

Injector Wire Colors

Injector Wires: Pink/Green – Pink/Yellow – Pink/Black – Pink/Blue

Ignition Switched Power Wire: Brown/White from taillight

Typical Settings

Low Speed Pot Setting: 1.0

Accelerator Pump Pot: 3.0

High Speed Pot: 2.0

High Speed RPM Set: 4500

Honda 99-02 CB1100XX

Injector Wire Colors

Injector Wires: Pink/Green – Pink/Yellow – Pink/Black – Pink/Blue

Ignition Switched Power Wire: Brown/White from taillight

Typical Settings

Low Speed Pot Setting: 3.0

Accelerator Pump Pot: 3.0

High Speed Pot: 2.0

High Speed RPM Set: 4500

Kawasaki 00-03 ZX12R

Injector Wire Colors

Injector Wires: Blue/Green – Blue/Yellow – Blue/Black – Blue/Red

Ignition Switched Power Wire: Red from taillight

Typical Settings

Low Speed Pot Setting: 2.0

Accelerator Pump Pot: 1.5

High Speed Pot: 1.0

High Speed RPM Set: 4500

Suzuki 01-02 GSXR1000

Injector Wire Colors

Injector Wires: Gray/White – Gray/Yellow – Gray/Black – Gray/Red

Ignition Switched Power Wire: Gray from taillight

Typical Settings

Low Speed Pot Setting: 2.0

Accelerator Pump Pot: 3.0

High Speed Pot: 1.0

High Speed RPM Set: 4500

**Phone: 407.330.9727 – Fax: 407.322.8632
5350 McIntosh Point #132 – Sanford, Florida 32773**

Suzuki 03 GSXR1000

Injector Wire Colors

Injector Wires: Gray/White – Gray/Yellow – Gray/Black – Gray/Red

Ignition Switched Power Wire: Gray from taillight

Typical Settings

Low Speed Pot Setting: 2.0

Accelerator Pump Pot: 2.5

High Speed Pot: 1.0

High Speed RPM Set: 4500

Suzuki 99-02 GSXR1300

Injector Wire Colors

Injector Wires: Gray/White – Gray/Yellow – Gray/Black – Gray/Red

Ignition Switched Power Wire: Gray from taillight

Typical Settings

Low Speed Pot Setting: 2.0

Accelerator Pump Pot: 3.0

High Speed Pot: 1.0

High Speed RPM Set: 4500

Yamaha 02-03 R1

Injector Wire Colors

Injector Wires: Blue/Black – Green/Black – Orange/Black – Red/Black

Ignition Switched Power Wire: Blue/Red from taillight

Typical Settings

Low Speed Pot Setting: 2.0

Accelerator Pump Pot: 6.0

High Speed Pot: 2.0

High Speed RPM Set: 4500

If you have any more questions we have a Frequently Asked Questions page at our web site as well as the telephone tech support. Thank you for your purchase of this MPS product. All products sold by MPS are for use at closed course competition events and not for use on public streets or highways.