



CAUTION: CAREFULLY READ INSTRUCTIONS BEFORE PROCEEDING

OVERVIEW

The WEGO II is a complete air/fuel ratio metering system with built-in data logging. The system is a versatile tuning aid and diagnostic tool for all carbureted and fuel injected gasoline powered engines. The WEGO II unit displays AFR (air/fuel ratio) and logs up to 3 hours data including AFR, engine RPM, and a spare 0-5V analog input for sensors such as throttle position or manifold pressure. A red LCD display with backlight provides great readability in all conditions ranging from bright sunlight to total darkness. The compact size and wide supply voltage range also allow operation from small rechargeable batteries in a broad range of applications.

The system uses a new low cost Bosch LSU 4.2 5-wire wide-band oxygen sensor. By utilizing miniature surface mount electronics technology, digital signal processing techniques, and a switching power supply for the sensor heater, the WEGO II provides the same level of accuracy as lab systems costing thousands of dollars.

WEGO II units also have a 0-5 volt analog AFR output that is compatible with the Twin Tec TCFI fuel injection controller for closed loop AFR control.

REPLACEMENT SENSORS AND ACCESSORIES

The WEGO II uses a standard Bosch LSU 4.2 sensor used on a VW production application (Bosch P/N 0 258 007 057/058 or VW P/N 021 906 262B). The proprietary VW connector is replaced with a smaller Deutsch DT-04-6P. We offer replacement sensors with the Deutsch connector installed.

If you are testing multiple engines, we also offer additional 18 x 1.5 mm weld nuts for sensor mounting and 18 x 1.5mm hex socket plugs that screw into the weld nuts and allow removing sensors after tuning.

Some engines using CD (capacitive discharge) ignitions may require a special tach adapter for engine RPM data logging. Please call our tech support at 386-304-0700 for details.

INSTALLATION

1. Turn off the ignition switch and disconnect the battery ground cable before proceeding.
2. Select a convenient mounting location for the Bosch sensor. In general, the sensor should be mounted as close to the exhaust valve or exhaust manifold as practical. When choosing a mounting location, allow several inches clearance for the sensor wire harness. The wire harness must exit straight out from the sensor. Do not loop the harness back onto the sensor body. The sensor responds to oxygen pressure. Excessive backpressure will cause a reading error. For turbocharged applications, you must mount the sensor downstream of the turbo.
3. An 18 x 1.5 mm weld nut must be welded onto the exhaust pipe. After welding, run an 18 x 1.5 mm tap through the threads. Failure to clean the threads may result in sensor damage. Note that most automotive muffler shops are familiar with oxygen sensor weld nut installation on custom pipes. Do not install the sensor until after the free air calibration procedure described in the following section. Always use an anti-seize lubricant such as Permatex 133A on the sensor threads.
4. Install the WEGO II unit. The WEGO II unit should be mounted where the LCD display will be visible during testing. You can secure the WEGO II unit with Velcro tape strips.
5. Connect the Bosch sensor to the 6 pin mating connector on the WEGO II wire harness.
6. Refer to Figure 1. Connect the black WEGO II wire to frame ground using the supplied ring terminal. Try to use an existing wire harness ground location. **Do not extend the WEGO II ground wire or ground the WEGO II to the battery minus terminal or to the engine.**
7. Connect the red WEGO II wire to switched +12 volt power. You can usually find switched +12V power at an accessory fuse on the fuse block. You can use the supplied fuse tap and 3/16" female crimp terminal for this purpose.

Figure 1 - WEGO II Hookup

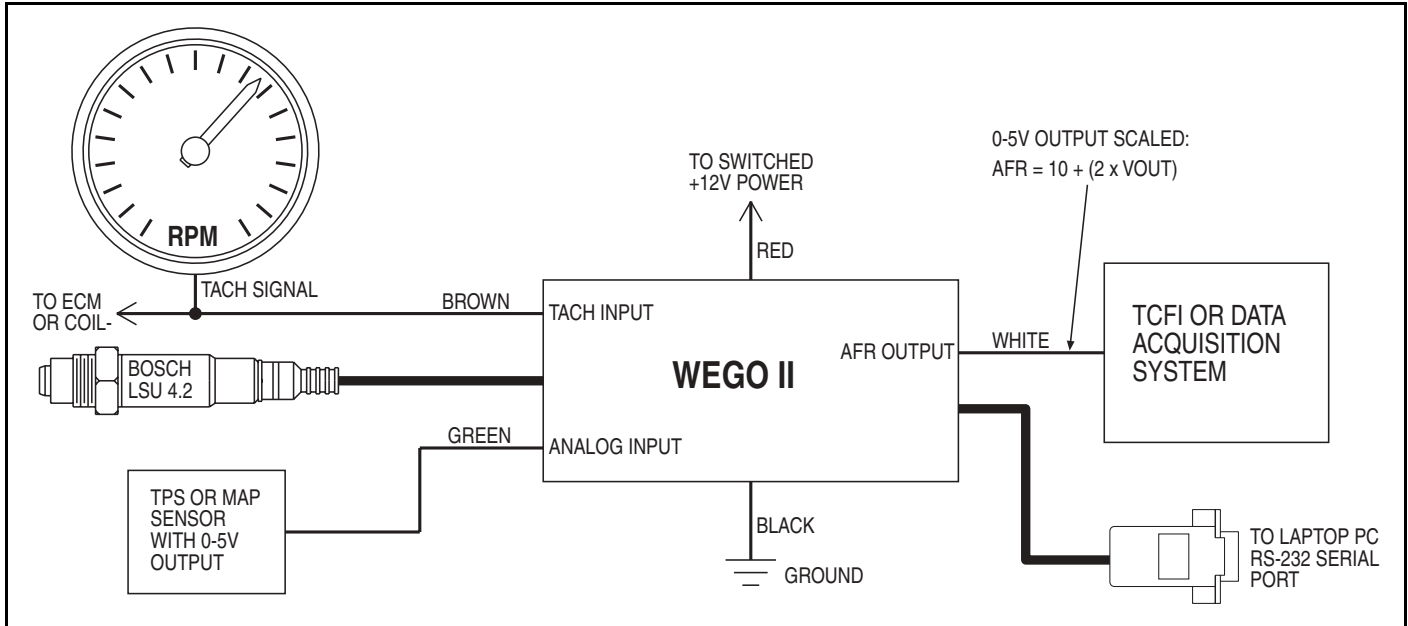

8. Optional signal hookups, including engine RPM and analog signal data logging, are explained in sections 9-11. If you are not using these features, tape up the brown, green, and white wires.
9. For engine RPM data logging, connect the brown WEGO II wire to one of the following:
 - a. **Tach signal (preferred for best noise immunity).** The unit is compatible with industry standard 12 volt square wave tach signals such as what would be used to drive an Autometer or similar aftermarket tach. Most aftermarket CD (capacitive discharge) ignitions including the MSD-6 and Crane HI-6 series have a tach output that you can connect to the WEGO II. 1999-2003 Harley-Davidson® motorcycles with carbureted Twin Cam 88® engines have a tach output on pin 12 of the black ignition module connector. 2001 and later Harley-Davidson® motorcycles with Delphi® fuel injection have a tach output on pin 3 of the ECM connector.
 - b. **Coil- terminal.** The unit is compatible with the signal on the Coil- terminal of most inductive discharge type ignitions. This includes most OE (original equipment) automotive ignitions and all Harley-Davidson® ignitions. For automotive distributorless or Harley-Davidson® single

- fire systems with multiple coils or coil packs, you can use any one of the Coil-signals.
- c. **Motorcycle and small engine CD (capacitive discharge) ignitions.** Many Japanese motorcycles and small engines use CD ignitions. Any engines with flywheel triggered systems fall into this category. These applications will require a special tach adapter P/N WEGO2-TACH-ADAPT. If you are not sure about your application, download the WEGO II Tach Adapter instructions from our website at www.daytona-sensors.com. Tips are provided for identifying the type of ignition system in use.

WARNING: Directly connecting the WEGO II brown wire to the coil of a CD type ignition will damage the unit and void the warranty.

The WEGO Log software is used to set the correct scaling for engine RPM in terms of pulses per revolution. The unit can easily be set up for operation with 1-12 cylinder engines. Refer to the WEGO Log instructions for details.

10. For analog signal data logging, connect the green WEGO II wire to one of the following:
 - a. **Throttle position sensor.** Most engine controls use a TPS (throttle position sensor) with a 0-5 volt signal range. Refer to your service manual for details.
 - b. **Manifold pressure sensor.** Most engine controls use a MAP (manifold pressure sensor) with 0-5 volt signal range. Refer to your service manual for details.
 - c. **Other 0-5V analog signals.** The WEGO II can log any 0-5V signal. For other sensors, use a scope meter to check the signal before connecting it to the WEGO II.

WARNING: Connecting the WEGO II green wire to a high voltage (in excess of 12 volts) will damage the unit and void the warranty.

The WEGO Log software is used to set the units and scaling for the analog input. Refer to the WEGO Log instructions for details.

11. Optional AFR output. The WEGO II can be used with Twin Tec TCFI fuel injection systems. You can connect the white wire from the WEGO II to the TCFI system for closed loop AFR control. Refer to the TCFI instructions.
12. Reconnect the battery ground cable.

OPERATION

For more information about wide-band oxygen sensors including the Bosch LSU 4.2, we suggest that you visit the Tech FAQ on our website at www.daytona-sensors.com.

The WEGO II has a red status LED. When power is turned on, the LED blinks at a slow rate until the attached sensor has reached normal operating temperature.

After installation, the WEGO II system requires free air calibration. This should be done with the sensor dangling in free air. The environment must be free of hydrocarbon vapors. We suggest that you perform the free air calibration outdoors. Turn the free air adjustment trimpot on the WEGO II full counterclockwise. Turn on power and wait until the LED stops blinking at a slow rate. Wait an additional 30 seconds for the system to fully stabilize. Then slowly

turn the free air calibration trimpot clockwise until the LED starts flashing at a rapid rate. Try to set the trimpot at the point where the LED just starts to flash. The display should now read 19.99 or blink (for over range).

Figure 2 - WEGO II Unit



The free air calibration procedure should be performed at reasonable intervals (every 250-500 hours) or whenever the sensor is replaced. If you cannot get the LED to flash when the trimpot is turned full clockwise, you either have a damaged sensor or very high hydrocarbon levels in your environment.

The WEGO II will start logging data once the sensor has reached normal operating temperature and the LED stops blinking. The interval between samples can be set from 0.1-1.0 seconds using the WEGO Log software. Refer to the WEGO Log instructions for details. The unit stores the last 8,000 samples.

The WEGO II includes internal diagnostics for abnormal battery voltage (less than 10 volts or greater than 16.5 volts), sensor open circuit, and sensor short circuit conditions. A fault condition causes the status LED to blink at the slow rate. The WEGO Log software displays the diagnostic codes.

EXHAUST CONSIDERATIONS

The WEGO II system may give inaccurate results in certain situations:

Excessive exhaust back pressure. Wide-band sensors are affected by back pressure. Excessive back pressure causes exaggerated AFR indications under rich and lean conditions, but has little effect at 14.7 AFR (stoichiometric). The WEGO II is intended to be used with a free flowing performance exhaust. Overly restrictive stock mufflers may cause excessive back

pressure under wide open throttle. When used with a turbo system, the sensor must be mounted downstream of the turbo.

Exhaust reversion. Reversion is the term for a negative pressure wave that can suck ambient air back into the exhaust and cause an erroneous lean AFR indication. Exhausts without mufflers, such as open headers or “drag pipes” on motorcycles, usually suffer from reversion effects and may not be suitable for use with the WEGO II. Reversion effects will also occur with certain exhausts used on “bagger” style motorcycles, where two pipes split off near the rear cylinder. You will have to block off the pipe running to the left side. Reversion effects will be most noticeable at idle, part throttle low RPM cruise, and decel.

Excessive scavenging. Turbo systems or tuned exhausts in combination with a high overlap camshaft profile can force unburned air and fuel mixture through the cylinder into the exhaust and cause an erroneous rich AFR indication.

Misfiring. If the AFR is so rich that the engine misfires, high levels of oxygen will remain in the exhaust gas and result in an erroneous lean indication.

APPLICATIONS

WEGO II units are useful in a wide range of engine tuning and testing applications. After free air calibration, accuracy is ±0.1 AFR over the 10.3-19.5 AFR range. The white wire is a 0-5 volt analog output scaled:

$$\text{AFR} = 10 + (2 \times \text{Vout})$$

For example, an output of 2.5 volts corresponds to 15.0 AFR. This scaling is convenient for many data logging systems. When power is first turned on and the sensor is not yet at its normal operating temperature, the analog output is held at less than 0.20 volts.

WEGO II units also feature low power consumption (about 1 amp) and a wide operating voltage range (11-18 volts). For small engine applications, you can power the WEGO II for several hours from a 12 volt gel cell type rechargeable battery, such as the type used for backup power in alarm systems.

CAUTION: WEGO II units are not sealed. These units are intended for dash mounting or use in dry environments. There is no warranty on units with moisture damage.

ENGINE TUNING GUIDELINES

Higher AFR values correspond to a leaner (less fuel) condition. The practical operating range for most engines using gasoline fuel is from approximately 11.5 to 14.7 AFR. Combustion of a stoichiometric mixture (exactly enough air to burn all the fuel) results in 14.7 AFR indication. Automotive engines with catalytic converters operate near 14.7 AFR during cruise and idle. Air-cooled motorcycle and automotive race engines usually require a richer mixture to limit cylinder head temperature and prevent detonation. The table below lists reasonable AFR values for engines without emission controls.

Operating Mode	Recommended AFR
Cold Start (first 30 sec)	11.5-12.5
Idle	12.8-13.5
Part Throttle Cruise	13.0-14.0
Wide Open Throttle	12.5-12.8 (values down to 11.5 may be used to reduce detonation)

EXHAUST SNIFFERS

WEGO II units can be used with easily fabricated exhaust sniffers that allow temporary installation on most automobiles and motorcycles for tuning and diagnostic purposes, including vehicles with catalytic converters. The exhaust sniffers are constructed from materials that are readily available at any hardware store. For more details, download the Automotive Exhaust Sniffer Tech Note and Motorcycle Exhaust Sniffer Tech Note from our website at www.daytona-sensors.com.

TROUBLESHOOTING FLOWCHART

Follow the troubleshooting flowchart shown on the next page. Experience has shown that most units returned for warranty are OK and another problem, such as user error, a degraded sensor, or bad power connections is later identified.

CAUTION: Racing gasoline containing lead will quickly degrade the sensor. Under these conditions, expected sensor life is less than 10 hours. There is no warranty on sensors.

Troubleshooting Flowchart

