

# Instruction Sheet

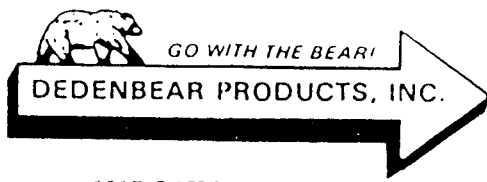

TSC-1

# Throttle Stop Controller

①

1917 OAK PARK BLVD.  
PLEASANT HILL, CA 94523  
(510) 935-3025

## INSTALLATION

- 1) Mount the Throttle Stop Controller away from heat, vibration & ignition wires. Fasten it with (4) #6 sheet metal screws. It can be mounted in any position, even upside down for overhead positions.
- 2) Wire as shown in the wiring diagrams. The trigger and GRND wire can be 18 gauge. All other wiring should be 10 gauge for throttle stops and 14 gauge for NOS, Clutch, or air shifter solenoids. It never hurts to use oversize wire. Make sure you have a good ground connection (grounding to the interior sheet metal is not reliable).

## OPERATION

When you apply 12 volts to the "trigger" input, the throttle stop controller is on. When you cut off 12 volts to the "trigger", both timers start & stay on until they time out. Although both timers are started from the same trigger, each one acts separately so they can even be used to run different equipment. If you want to use the timer in an application that is not shown, the following explanation will help you:

The outputs of the timers are contacts on a relay. "C" stands for common and it is the arm of the relay that switches between the 2 contacts. "NC" stands for normally closed. "NO" stands for normally open. "Normally" means that the relay is just sitting there with no power applied to the coil. Closed means that the common & the closed contact are touching each other so power can flow. Open means the common & the open contact are not touching so no power can flow. When you put power to "trigger", the common arm swings down & connects to the "open" contact. You can ground the common or put power to it depending on your application. The two timer relays are separate so they can be run independently or they can be tied together to give any timing sequence. Never tie the relays together if one has power and the other ground because they will short circuit & burn up the unit.

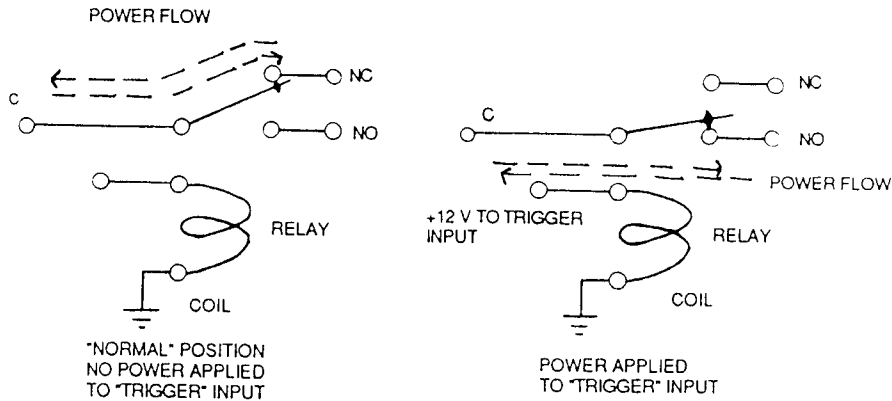

## WARNING:

**Do not use this unit to control trans brakes or line locks because there is no safety circuit to prevent brake application due to a malfunction.**

(USE THIS DIAGRAM FOR "BASEPLATE" STYLE STOPS.)

STANDARD SET-UP  
USE WITH THROTTLE STOP, SOLENOID SHIFTER, OR ELECTRONIC THROTTLE STOP

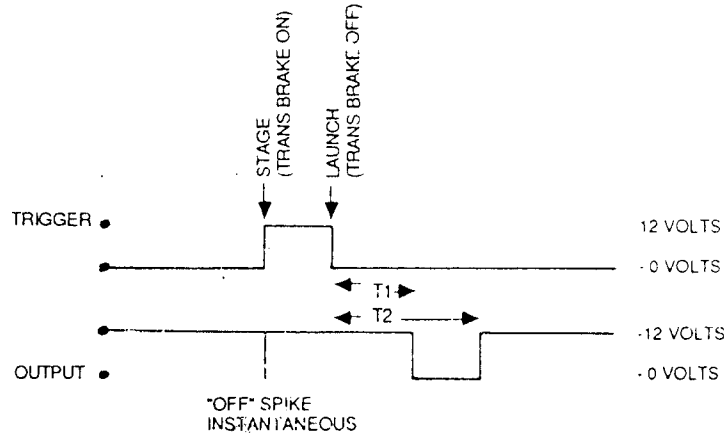
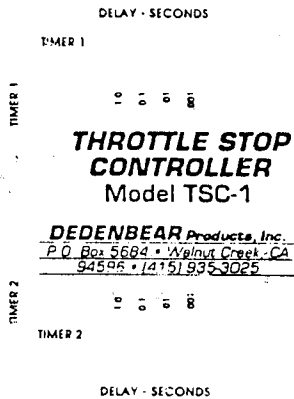
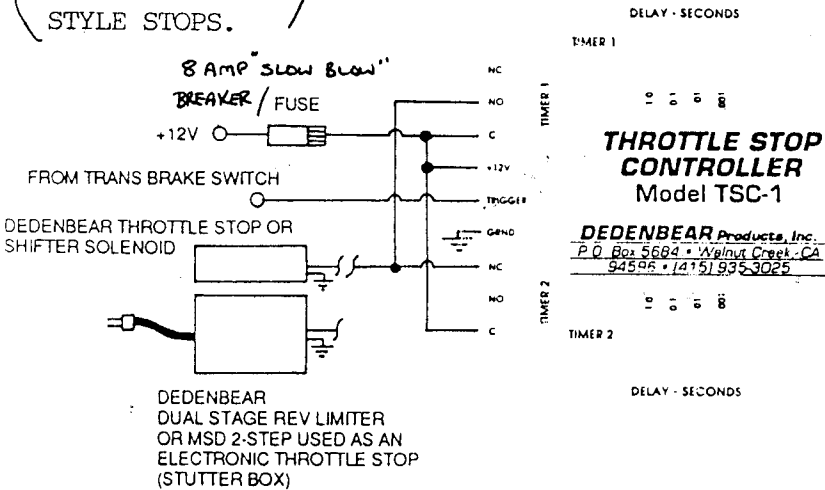

# WIRING DIAGRAMS FOR

## WIRING

FOR USE WITH AIR SHIFTER OR NOS SYSTEM

(USE THIS DIAGRAM FOR "LINKAGE" STOPS.)

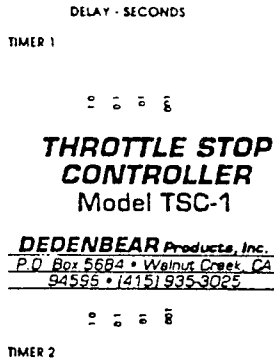
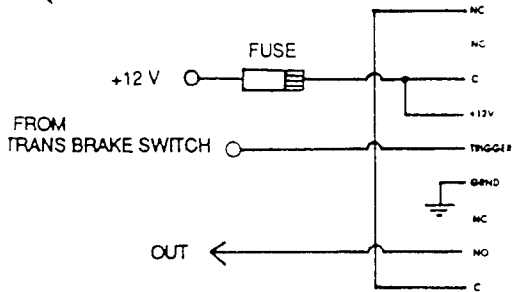

## OUTPUT

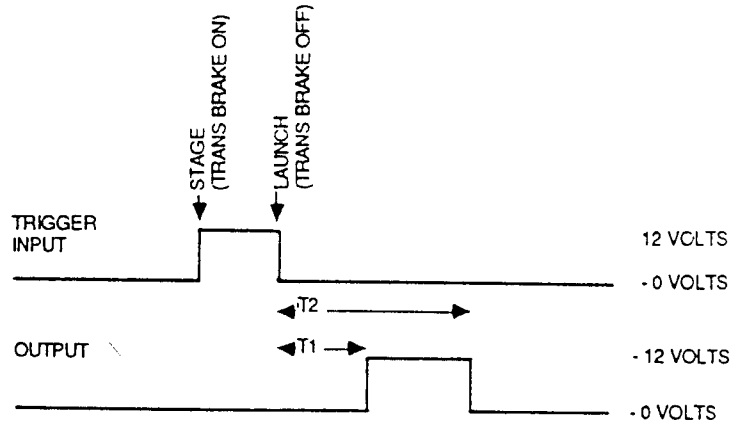

\*Warning: Do Not use as starting line control & mid-track control unless you use a relay.  
 Call us if you have any questions.  
 (510)935-3025  
 DEDENBEAR PRODUCTS

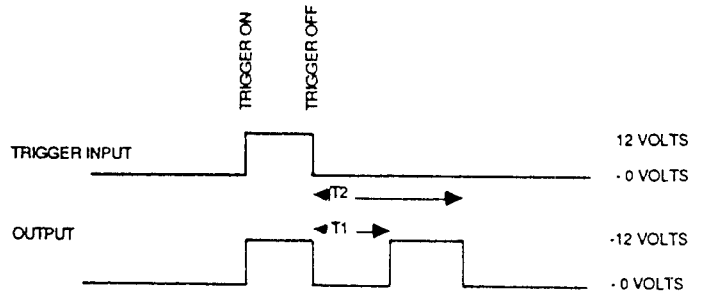
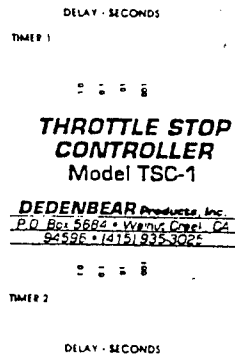
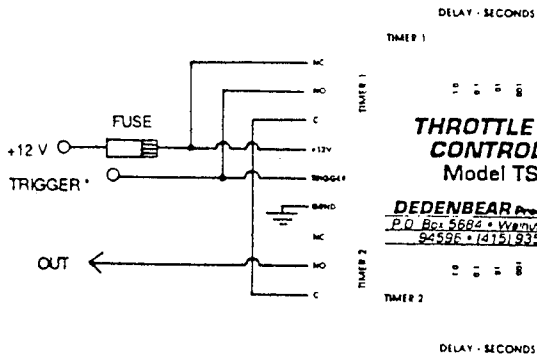

\* WARNING DO NOT TRIGGER BY USING THE TRANS BRAKE SWITCH OR CIRCUIT

## DUAL OUTPUT

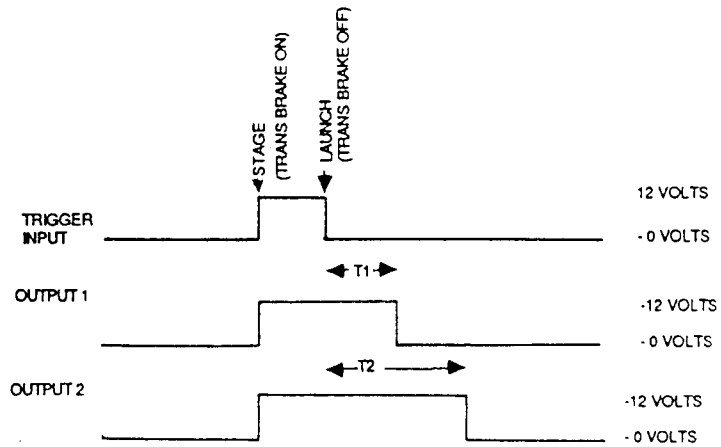
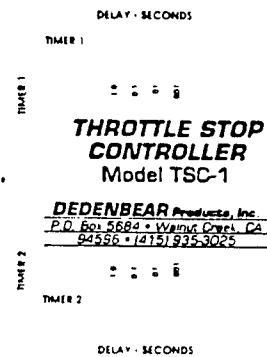
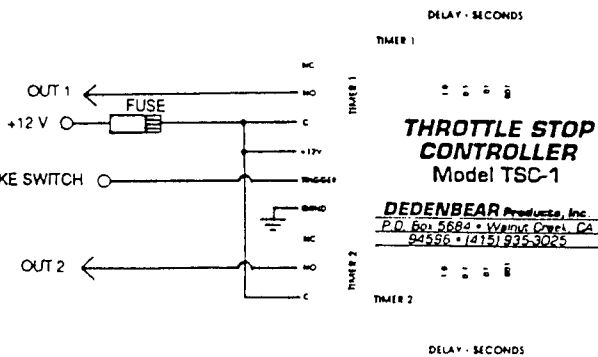

# DIFFERENT TYPES OF OUTPUT

## WIRING

## OUTPUT

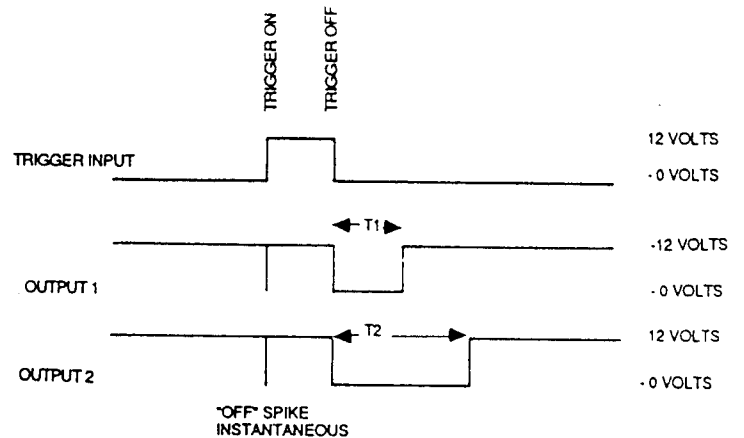
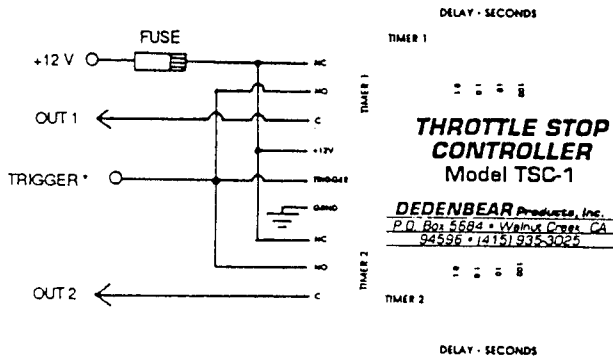
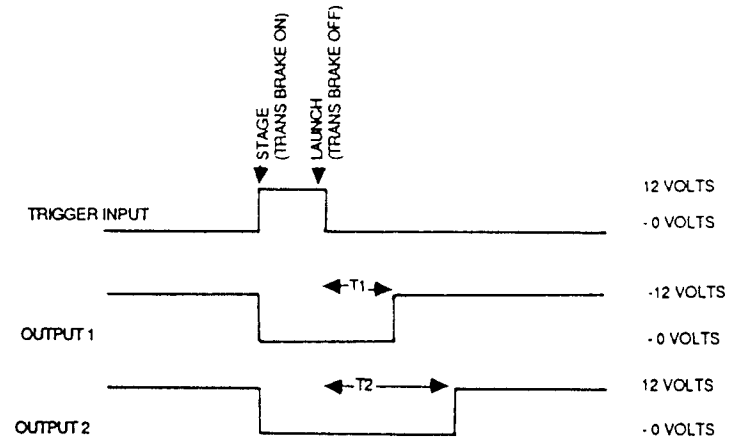
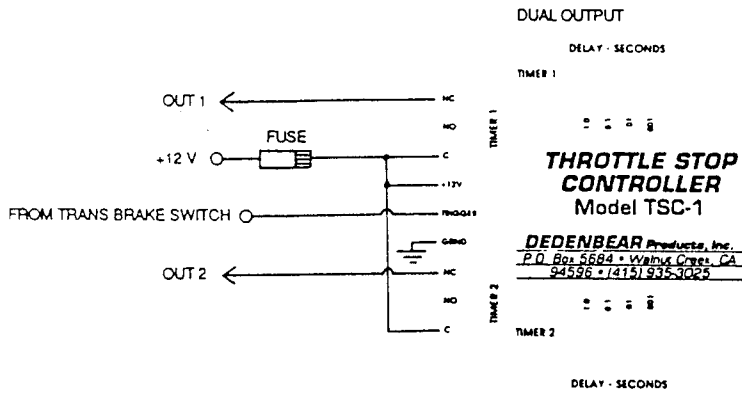

\*WARNING DO NOT TRIGGER BY USING THE TRANS BRAKE SWITCH OR CIRCUIT

OFF SPIKE INSTANTANEOUS

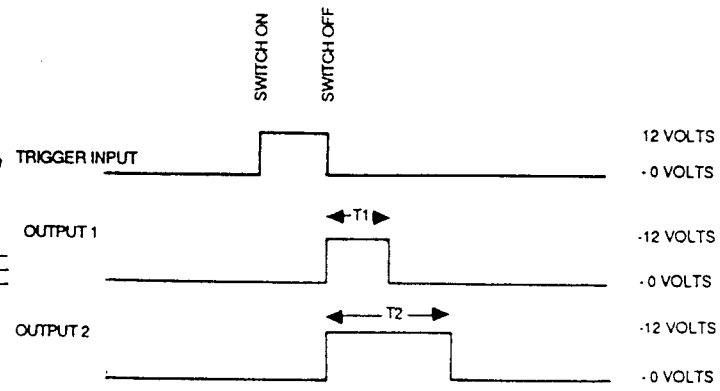
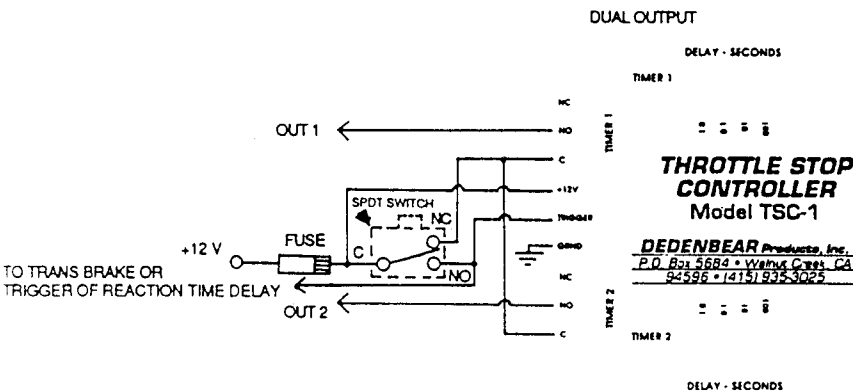

TO TRANS BRAKE OR TRIGGER OF REACTION TIME DELAY

4

DUAL OUTPUT  
FOR 2 STAGE AIR SHIFTER,  
2 STAGE NOS SYSTEM  
OR MULTI STAGE LOCK-UP CLUTCH

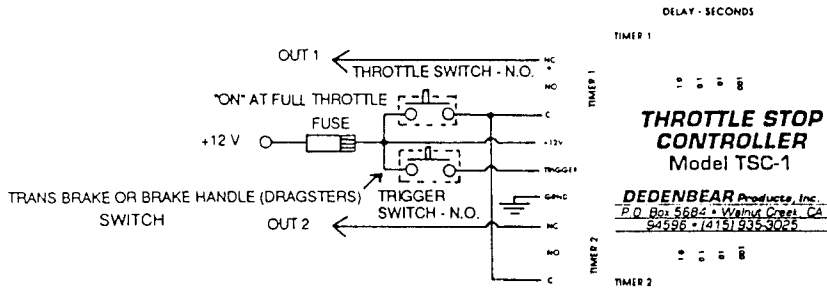

\*WARNING - OPERATES AS SHOWN AT WIDE OPEN THROTTLE ONLY. IF YOU LIFT OFF FULL THROTTLE, POWER OUTPUT IS CUT OFF. FULL THROTTLE REAPPLICATION RESTORES POWER OUTPUT INSTANTLY

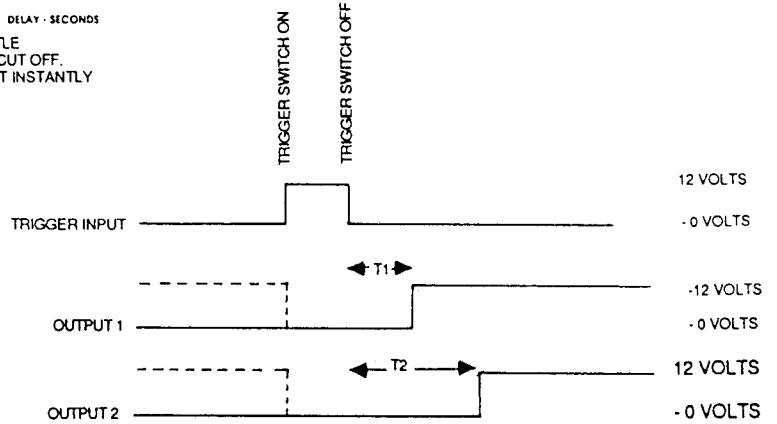

NOTE: OUTPUTS GIVE 12 VOLTS ONLY WHEN THROTTLE SWITCH IS ON (FULL THROTTLE)

.... DOTTED LINES ARE THE OUTPUT IF THE THROTTLE SWITCH IS ON (FULL THROTTLE) BEFORE THE TRIGGER SWITCH IS "ON".

### WARRANTY

The Dedenbear Products Throttle Stop Controller is warranted against defective materials or workmanship under normal use and service for a period of ninety (90) days after purchase. Dedenbear Products will repair or replace the defective unit, at Dedenbear Products option, free of charge.

DEDENBEAR PRODUCTS SHALL NOT BE LAIBLE FOR INJURY, CONSEQUENTIAL, OR OTHER TYPE DAMAGES RESULTING FROM USE OF ITS PRODUCTS, OTHER THAN THE LIABILITY STATED ABOVE. This warranty is in lieu of all other warranties of merchantability or fitness for use. This warranty gives you specific legal rights, and you may also have other rights which vary from state to state.

NOTE: IF TSC-1 IS BEING USED ON A "AIR" throttle STOP, A POWER RESISTOR MUST BE USED ON THE OUTPUT. PLEASE CALL IF NEEDED.