

DYNA III ELECTRONIC IGNITION INSTALLATION INSTRUCTIONS

PART NO. D35-1 FOR 1970 TO 1978 BMW MOTORCYCLES

The DYNA III System was designed for use with stock coils, however, it may be used with other coils or combinations of coils that have at least THREE OHMS primary resistance.

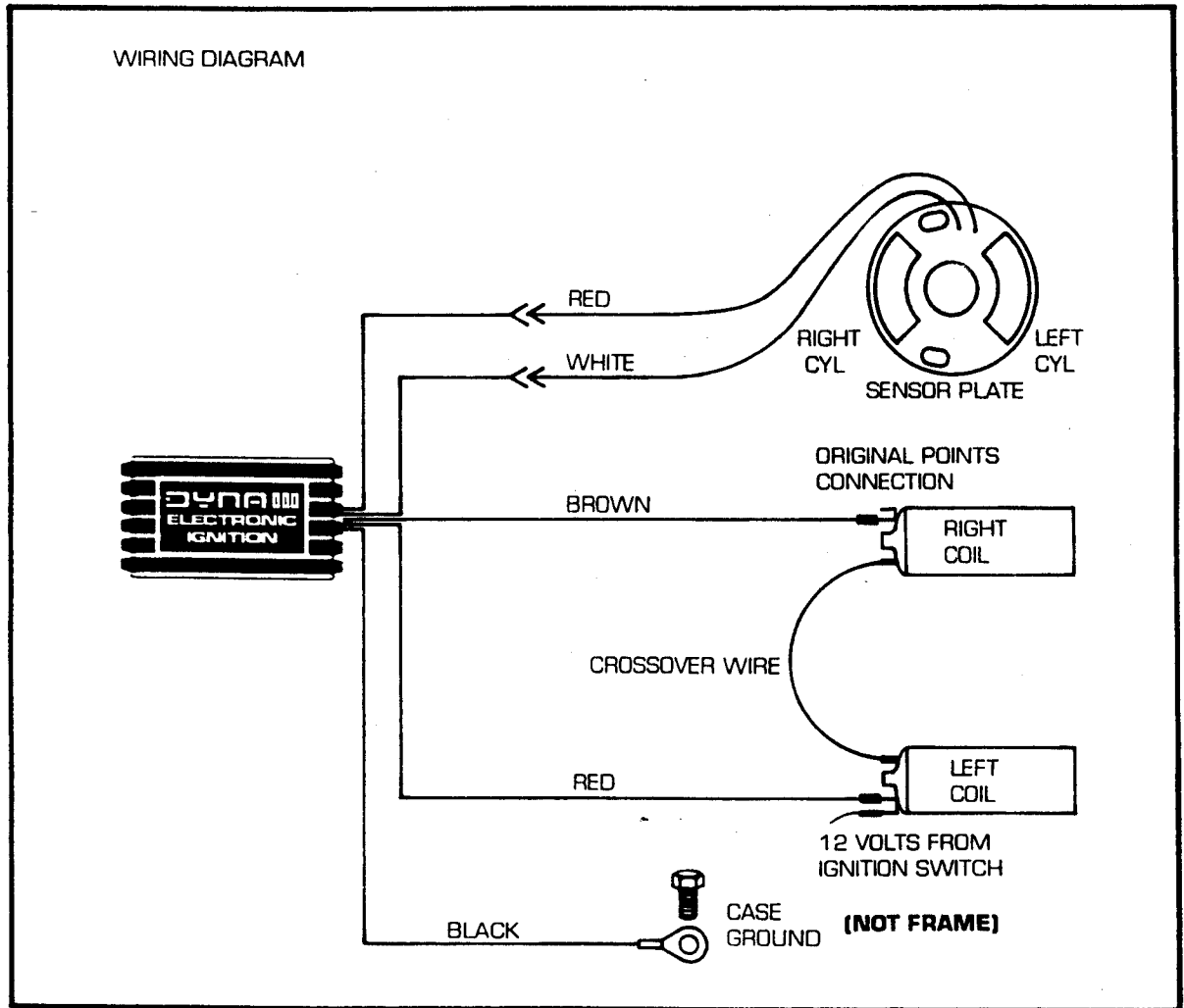

PROCEDURE-

- 1) Fasten the clamp to the electronic module using the 4-40 x 5/16 screws and locknuts provided. The clamp and nuts go on the inside of the case.
- 2) Attach the module to the frame in the location selected. Cut off excess clamp material.
- 3) Remove an engine case bolt and fasten the ground lug (black wire) securely to the engine. Do not attach to frame or carburetors.
- 4) Remove the fuel tank. Remove three allen screws and take off the generator cover.
- 5) Remove the 10 mm nut holding the advance assembly to the engine and remove the assembly.
- 6) Remove the 2 screws holding the point plate to the engine. Unplug the point wire from the condenser and pull the wire out of the rubber boot.
- 7) Install the DYNA III sensor plate using the 2 screws previously removed. Route the 2 wires up through the rubber boot. Pass the wires behind the rectifier and out through the cable grommet at the top of the engine case. Connect the wires to the corresponding red and white wires of the electronic module, matching the colors.
- 8) Connect the red wire from the module to the spare terminal on the left coil where the switched 12 volts is applied to the coils. NOTE: Do not connect to the crossover wire terminal.
- 9) Remove the wire that connects the condenser to the ignition coils, at the coil end. Connect the brown wire from the module to the coil terminal.
- 10) Place the advance assembly on a surface with the point cam pointing up. Notice that there are 2 metal restraining straps spot welded to the assembly. Using a screwdriver or similar instrument, bend the center of the straps down slightly so as to restrict the longitudinal movement of the cam when the advance assembly is reinstalled.
- 11) Slip the DYNA III rotor over the point cam, with the raised boss toward the advance weights. Hold the advance assembly so that the cam is pointing toward you, and sight down the hole through the center of it. Observe the "D" hole at the end of the advance assembly. Rotate the rotor until the set screws straddle the cam lobe adjacent to the flat of the "D" hole. With the rotor all the way down, turn the set screws alternately until tight, using the allen wrench supplied with the kit. Do not overtighten as it will distort the cam and impair advance operation.

- 12) Install the advance/rotor assembly on the engine, making sure the shaft has engaged the "D" hole. Reinstall the 10 mm nut and tighten.

TIMING-

NOTE:

- A) Refer to owner's manual for additional timing information.
 - B) The right sensor (left when viewing the installed sensor plate,) triggers the right cylinder, the left sensor triggers the left cylinder and each provides ± 10 degrees of adjustment. Moving them or the plate counterclockwise will advance the timing and clockwise movement retards the timing.
 - C) Ground circuit on back of sensor plate must be in contact with engine in order for ignition to operate.
 - D) The sensor to rotor air gap is not critical as long as there is no contact between the parts. There should generally be .020 to .040 inch between them.
 - E) Ensure that sensor plate wires are out of the way so that the advance weights will not interfere with them, and that they will not be crushed when the cover is replaced.
- 1) To time the engine statically, connect a 12 volt test light from the brown coil wire to ground.
 - 2) Remove the timing mark inspection hole plug, and loosen spark plugs. Rotate the engine until the right cylinder is on compression stroke and the "S" mark on the flywheel is aligned with the mark on the engine case.
 - 3) The leading edge of the magnet in the rotor should be near the center of the right cylinder sensor. If it is not, adjust the position of the rotor on the advancer.
 - 4) Turn ignition switch on. Turn the engine through 45 degrees against the normal direction of rotation and then in the forward direction. The light should come on when the "S" mark aligns with the mark on the engine. If not, loosen the two screws holding the sensor plate, rotate the plate to compensate for the error, and retighten screws. Recheck and readjust as necessary, remembering that .010 inch movement at the sensor approximately equals 1 degree of timing.

TIMING CONTINUED-

- 5) After adjustment of right cylinder timing, rotate the engine 360 degrees. The light should again come on as the "S" mark aligns. If not, loosen the nuts holding the left cylinder sensor block, move the block up or down as necessary and gently retighten nuts. Recheck and readjust as necessary.
- 6) The engine can also be timed dynamically using a strobe light in the normal manner.
- 7) Replace fuel tank, generator cover, timing hole plug, and tighten spark plugs.

NOTE:

A bad seal in the front cover of a BMW will allow water from rain or washing to enter the area where the DYNA III sensor plate is located, and since there is no drain hole provided, the water will become trapped. Eventually through electrolysis, it will dissolve the 12 volt printed circuit on the DYNA III sensor plate.

We recommend drilling a small hole on the bottom side of the cavity to provide a vent and eliminate the accumulation of moisture.

DYNATEK

164 S. VALENCIA ST.
GLENORA, CA 91741
(626) 963-1669