

DYNATEK SHIFT COUNTER

P.N. DSC-1

USER INSTRUCTIONS

GENERAL DESCRIPTION

The DYNATEK Shift Counter is a stand alone device that is useful for implementing shift control functions on drag racing vehicles. The Shift Counter has two major functions:

- Built-in programmable electronic shift kill to momentarily interrupt ignition system operation during shifts (replaces air kill switches). Includes 1-2 auto and 1-2-3 auto modes.
- Gear indicator outputs allow other systems to be triggered according to which gear the transmission is in.

The Shift Counter must be used with an electric switching valve on the air shifter and the associated electric shift button on the handle bar (electric over air setup). The Shift Counter gets its shift signal from the electric shift button.

The programmable shift kill function of the Shift Counter allows you to select a shift kill time from 60 to 90 milli seconds to meet the needs of your vehicle. The Shift Counter produces the selected kill time with extreme accuracy and can never vary. When in 1-2 auto mode, the Shift Counter simply deletes the kill on the first shift. Similarly, in 1-2-3 auto mode, the Shift Counter deletes the kill on the first two shifts. This is an ideal (and simple!) way to control a semi-auto trans.

The Shift Counter's gear selector outputs consist of five screw terminals on the end of the box. When you are in 1st gear the first screw terminal is a source of +12 volts that can be used to activate other systems. When you are in second gear the second screw terminal is activated, etc. There are two modes for the output terminals - Single and Add. In Single Mode only the screw terminal for the gear that you are currently in is active. In Add Mode once a terminal is activated it stays active even when you shift into the next gear. Single or Add Modes are chosen depending on how you want to activate other systems. For example, on a multi stage nitrous system or multi stage waste gate system you would use Add Mode so as to keep previously activated stages active when you shift to the next gear. If you are activating stages of retard you may want to use Single Mode so that only one output at a time is active.

INSTALLATION

The Shift Counter is simple to install. You must use an electric over air shift system with the Shift Counter. Before installing the Shift Counter it is suggested that you have already installed an electric over air shift system and verify that it is functioning properly.

1. Mount the Shift Counter somewhere near your ignition module. The Shift Counter has been designed to be plug in compatible with the DYNA 4000 Pro ignition.

REFER TO THE INCLUDED WIRING DIAGRAM DURING THE FOLLOWING STEPS

2. Locate the two wire Black and Red extension harness that came with your Shift Counter kit. This is the main power and ground for the Shift Counter. Plug the terminated end of this harness into the mating two position plug on the Shift Counter. The Red wire in this harness should be connected to a source of switched +12 volts. This is normally connected to the same +12 volt supply wire that feeds your ignition module. Connect the Black wire on this harness to a good ground. Either directly to the battery or to a good ground point that is in turn connected to the battery.
3. Locate the purple extension wire supplied with your kit. This is the trigger input that tells the Shift Counter that you are shifting. Connect the terminated end of this wire to the mating connector on the Shift Counter. Splice the other end of this wire to the side of your electric switching valve that is fed from your handle bar shift button. Your electric switching valve should be wired such that when you push the handle bar shift button, +12v is fed to both the switching valve and the purple wire of the Shift Counter.

DYNATEK

164 S. VALENCIA ST. • GLENDORA, CA 91741 • (818) 963-1669 • FAX (818) 963-7399

4. Follow this step if you have a DYNA 4000 Pro ignition, otherwise skip to step 4b. Locate the two pin plug on the Shift Counter that has an Orange and Black wire. This is the shift kill output. Plug this output directly to the mating kill input on the DYNA 4000 module. That's it you're installed. Skip to the next section - **SETTING THE SHIFT COUNTER MODES.**

4b. If you do not have a DYNA 4000 Pro ignition read this step. The Shift Counter can be adapted to other ignitions by understanding how the kill output works. The kill output of the Shift Counter consists of an Orange and Black wire. The Black wire is a ground. The Orange wire is pulled low (grounded) by the Shift Counter only during the kill period. The Orange wire can be used to activate a relay during the kill period which in turn can be used to shut off power to coils, ground a magneto, or otherwise interrupt ignition operation to implement a shift kill.

5. SETTING THE SHIFT COUNTER MODES

The Shift Counter has 5 DIP switches that are used to select the proper operating mode. The DIP switches are located under the top cover of the Shift Counter. To access the DIP switches, remove the four screws that secure the cover and remove the cover.

Switch 1 - Output Mode

mode	SW1
Single Mode	OFF
Add Mode	ON

In Single Mode only the output for the currently selected gear will be active. When you leave a gear the output for that gear will be deactivated.

In Add Mode outputs will remain active after shifting into a higher gear. When you get to high gear all outputs for lower gears will still remain active.

Switch 2 and 3 - Kill mode

mode	SW2	SW3
Manual Mode	OFF	OFF
1-2 Auto Mode	OFF	ON
1-2-3 Auto Mode	ON	OFF

In Manual Mode a shift kill period will be generated for all shifts. In 1-2 Auto Mode there will not be a kill during the first shift. In 1-2-3 Auto Mode there will not be a kill during the first two shifts.

Switch 4 and 5 - Shift Kill Time Selection

mode	SW4	SW5
90 milli Second Kill	OFF	OFF
80 milli Second Kill	OFF	ON
70 milli Second Kill	ON	OFF
60 milli Second Kill	ON	ON

The selected shift kill time will be generated at the appropriate shifts. The Shift Counter generates a very accurate kill time that can never vary. When in doubt which kill time to select start with a long kill time and work your way to a shorter time. If the kill time is too short, the vehicle may not shift correctly.

TESTING THE SHIFT COUNTER

The Shift Counter is easy to test. To test the output modes simply turn on ignition power (don't start the engine and don't put air in the shifter during this test). Push the shift button on the handle bar and watch the LED output indicators on the top of the Shift Counter. You will see the Shift Counter progress through the gears each time you push the button. The Shift Counter always starts in first gear upon power up. Even if you do your burn out in another gear, The Shift Counter will remain set to first gear as long as you don't shift using the air shifter. Try both Single and Add modes and watch how the LEDs respond differently as you shift.

TESTING THE SHIFT COUNTER (continued)

If you are using the shift kill function of the Shift Counter try the above test with the engine running (do not put air in the shifter during this test). Each time you hit the shift button the engine will die for an instant when a shift kill period is generated. To reset the Shift Counter turn off ignition power then turn it back on.

ACTIVATING OTHER SYSTEMS WITH THE SHIFT COUNTER

The output terminals on the Shift Counter are provided to activate other systems according to which gear you are in. But, these outputs are not designed to drive high current loads such as solenoids. Each output on the Shift Counter is designed to supply up to 100 milli Amps (.1 Amps). This is enough to drive relays, retard boxes, or other small current devices. If you wish to activate devices which require more activation current than 100 milli Amps you must use a relay between the Shift Counter and the other device. For example:

USING A RELAY TO ACTIVATE A SOLENOID

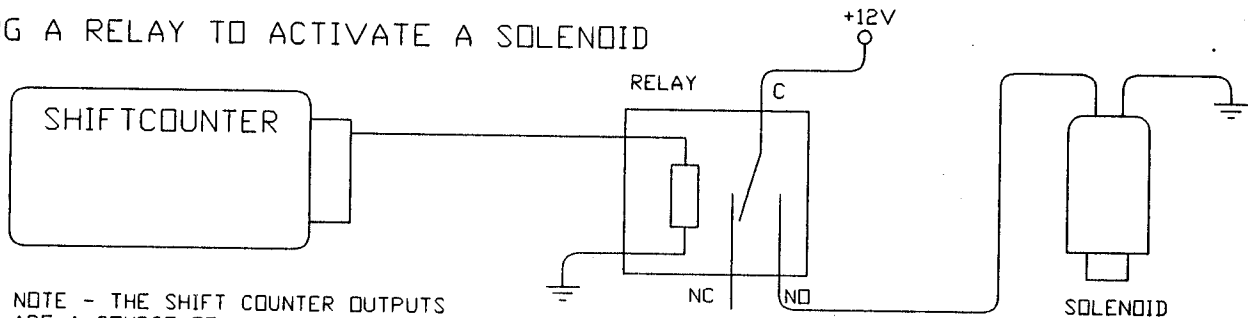

NOTE - THE SHIFT COUNTER OUTPUTS ARE A SOURCE OF +12 VOLTS WHEN THEY ARE ACTIVE
CAUTION - DO NOT DIRECTLY DRIVE A LOAD OF MORE THAN .1 AMPS WITH ANY ONE SHIFT COUNTER OUTPUT

Activating one device in more than one gear.

You can connect one device to more than one output of the Shift Counter if you are operating the Shift Counter in Single Mode. For example, if you wanted one stage of a retard box active in 1st gear and the second stage active in 2nd and 3rd gear, you would hook it up as follows:

CONNECTING ONE DEVICE TO MORE THAN ONE OUTPUT

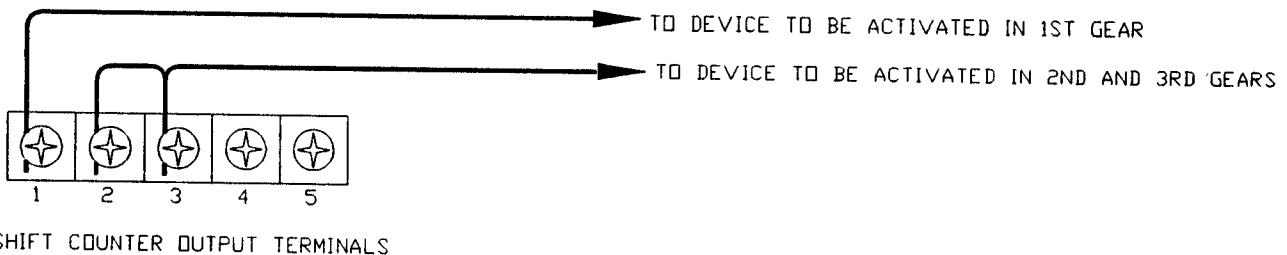

SHIFT COUNTER OUTPUT TERMINALS

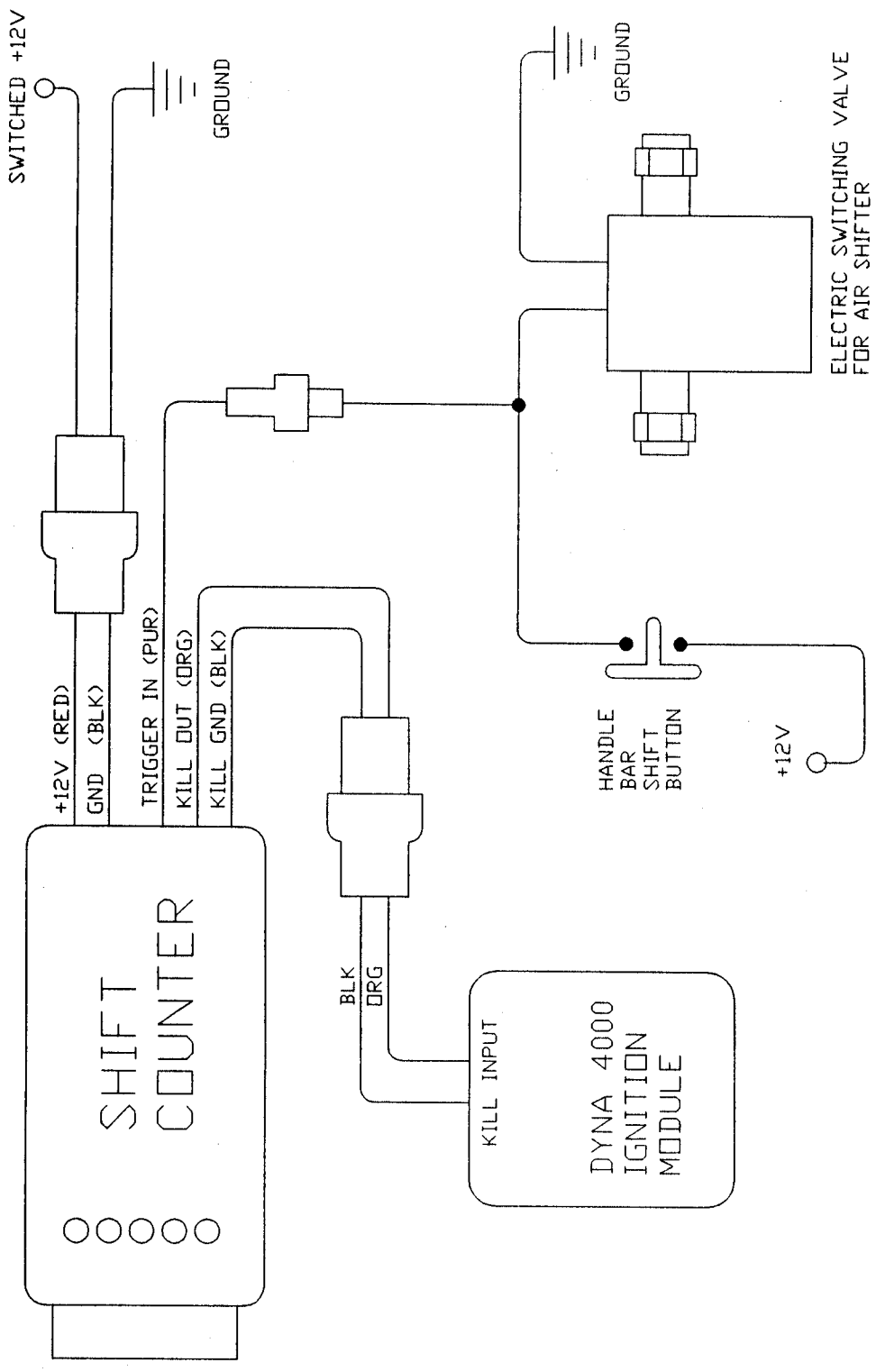

DYNATEK	
164 S. VALENCIA ST. GLENDORA CA 91741 (818)963-1669	
TITLE	SHIFT COUNTER WIRING
DATE	DRAWING NO.
8/17/95	SHFTCTR1.DWG
REV	1.0