

FUEL INJECTION INLINE FUEL PUMP REPLACEMENT INSTRUCTIONS

PRECAUTIONS FOR FUEL SYSTEM SERVICE

TO REDUCE THE RISK OF FIRE AND PERSONAL INJURY IT IS NECESSARY TO OBSERVE THE FOLLOWING PRECAUTIONS:

- Perform this repair ONLY in a properly equipped service facility.
- Position the vehicle in a clear, level, well ventilated work area.
- Make sure there are no sources of spark or combustion near the work area.
- Perform work in a no-smoking area, or post no-smoking signs in the area selected.
- Have readily available a fully functional Class B fire extinguisher of adequate size (such as a 5 pound CO-2 as a minimum).
- Disconnect the ground cable from the vehicle's battery before performing any operation involving gasoline, gasoline tanks or gasoline lines.
- Allow the vehicle to cool before performing any operation which could possibly expose gasoline or gasoline vapors to hot parts such as catalytic converters, hot light bulbs, or similar components.

- Avoid using extension cords or lights which might overheat or cause sparks.
- Avoid inhaling gasoline fumes and prolonged skin contact with gasoline. Promptly wash any body areas which have been in contact with gasoline.
- Wear approved safety glasses while performing any repairs.
- When raising the vehicle to perform under-vehicle services, use proper hoisting or jacking equipment along with approved safety supports.
- When removing the gasoline from a fuel tank use an OSHA approved pump which is specifically designed for handling gasoline. DO NOT USE any other type of pump. Gasoline removed from a fuel tank must be stored in approved gasoline containers.

It is impossible to anticipate all possible risks and conditions under which repairs may be made to a fuel system. Therefore, in addition to the safety concerns listed, you are urged to carefully evaluate the hazards involved in such a service procedure and take whatever further precautions that may be necessary.

WARNING: This rotary fuel injection pump WILL NOT work on carbureted fuel systems. It is for electronic fuel injection only.

CAUTION: Read these instructions thoroughly from start to finish before attempting to replace the fuel pump.

MINIMUM TOOL REQUIREMENTS

- Hoist or end lift-jack
- OSHA approved safety stands
- OSHA approved fuel transfer pump
- OSHA approved fuel storage containers
- Variety of mechanics hand tools

I PREPARATIONS

Relieve fuel system pressure system. (This procedure is necessary since the fuel system can retain gasoline under pressure for a considerable period of time. Opening a pressurized line could spray fuel creating a risk of fire and/or personal injury).

- 1) Start engine.
- 2) Remove the fuel pump relay allowing the engine to run until it quits. When engine quits, the fuel system pressure has been relieved. Turn the ignition switch off.
- 3) Remove the battery ground (-) cable for safety.
- 4) Reinstall the fuel pump relay.

II DISCONNECT ELECTRICAL CONNECTIONS

Review markings on the pump being replaced for + and - electrical connections. Mark the wires + or - at this time so that the proper polarity is maintained for the new pump.

Disconnect electrical connections from the pump.

III DISCONNECT FUEL LINE CONNECTIONS

CAUTION: Fuel lines may still be under slight pressure. Place a rag or shop towel around the fuel line connection to avoid excess fuel spillage.

IV REMOVE PUMP FROM VEHICLE

CAUTION: A residual amount of fuel is retained in the fuel pump when it is removed from the vehicle. Therefore the pump must be kept away from fire, flame, heat and sparks. The pump must also be disposed of in an environmentally correct manner.

V FUEL PUMP ISOLATOR

Slip the provided rubber isolator sleeve over the body of the new pump.

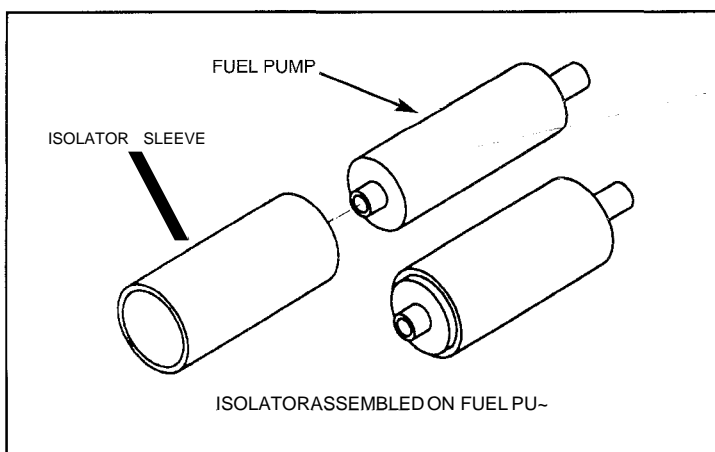

VI ATTACH THE INLET AND OUTLET FITTINGS TO THE PUMP

Observe the inlet and outlet fitting on the pump that is being replaced. Screw the proper fittings supplied in the pump kit into the new pump inlet and outlet using the new brass ring seal provided.

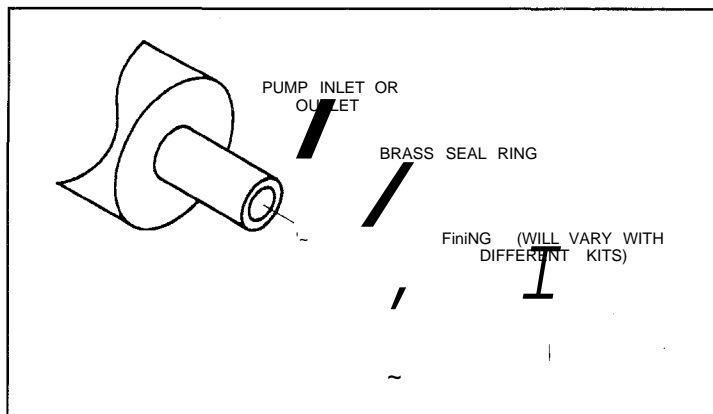

VII INSTALL THE FUEL PUMP ON THE VEHICLE

Using the existing brackets and hardware attach the new pump to the vehicle in the original location.

VIII ELECTRICAL CONNECTIONS

The new pump has different size terminals from the pump being replaced. As a result the ring terminals on the vehicle wiring harness need to be replaced by clipping the wire as close to the terminal as possible, stripping 1/4 inch of insulation from the wire and crimping on the new terminals with a proper crimping tool. Observing proper polarity, securely attach the ring terminals to the pump terminals with the provided nuts. Do not over tighten. Do not remove the nuts or the plastic isolators attached to the pump as delivered from the factory. This fuel pump must be installed in a fused circuit.

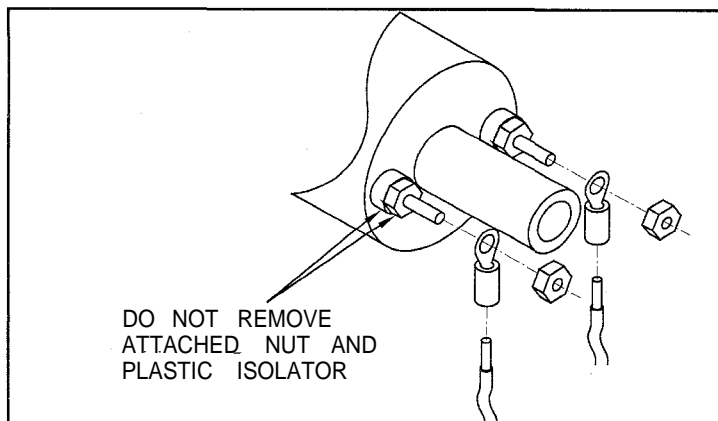

IX ATTACH FUEL LINES TO THE PUMP

Using the hardware on the vehicle, attach the fuel lines to the pump inlet and outlet. Be careful to establish a leak free connection.

X CHECK INSTALLATION

Start the vehicle and check for leaks. Refer to the vehicle service manuals for information on clearing any resultant error codes.