

MSD IGNITION INSTALLATION INSTRUCTIONS

MSD Dual Delay Timer PN 7563

Parts Included:

1 - Dual Timer Delay

1 - Parts Bag

WARNING: Before installing the MSD Timer, disconnect the battery cables. When disconnecting the battery cables, always remove the Negative (-) cable first and install it last.

The Dual Delay Timer allows you to activate two different circuits based on time (Channel 1 and Channel 2). Each Channel can be used to activate (supply a ground source) or deactivate (remove the ground) at a programmed time. The time is adjustable down to 0.01-second increments.

Note: To control devices that require over 2 amps, a relay will be required. MSD offers a SPDT 30 Amp/12 Volt DC as PN 8961 or a DPDT 30 Amp/12 Volt DC as PN 8960.

WIRING	
RED	This is the On/Off wire. Connects to switched 12 volts.
BLACK	Connects to a good ground source.
LIGHT BLUE	Resets the timer to zero when switched to 12 volts.
DARK BLUE	Starts the timer when removed from 12 volts.
YELLOW	Channel 1 Output, switches ground, 2 amps max
GRAY	Channel 2 Output, switches ground, 2 amps max

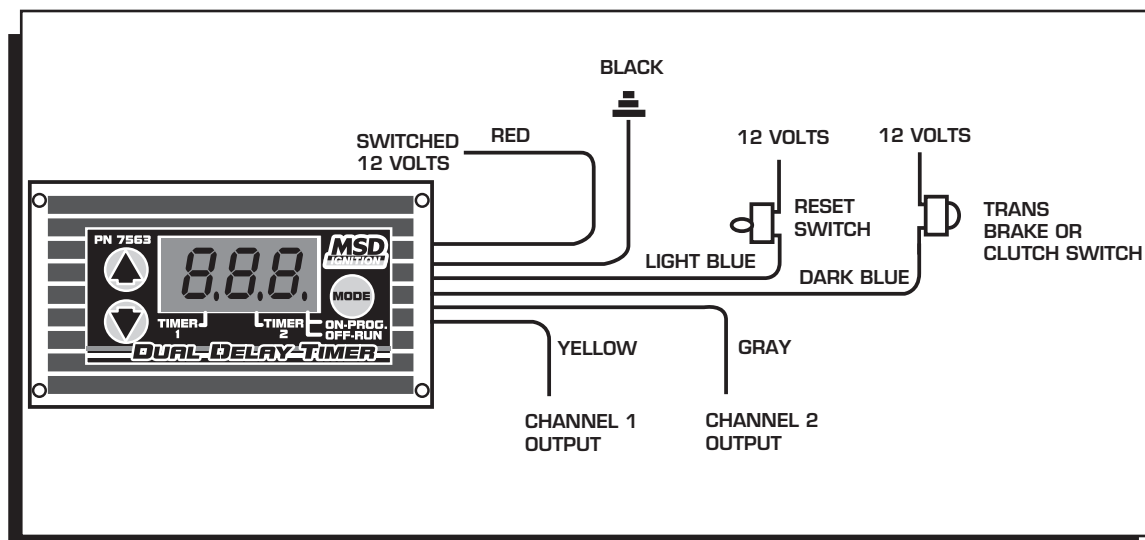

Figure 1 Basic Wiring of the Dual Delay Timer.

PROGRAMMING

When the Timer is turned on, three dashes will appear across the monitor. The Mode button switches between the programming stages. First you select Channel 1 or Channel 2 by pressing Mode, followed by the up or down button.

Once a Channel is chosen, press Mode again to select between On or Off. This determines if the ground is connected (On) or removed/open (Off). Pressing Mode again will take you to the time setting which can be set from 0.01 - 9.99 seconds.

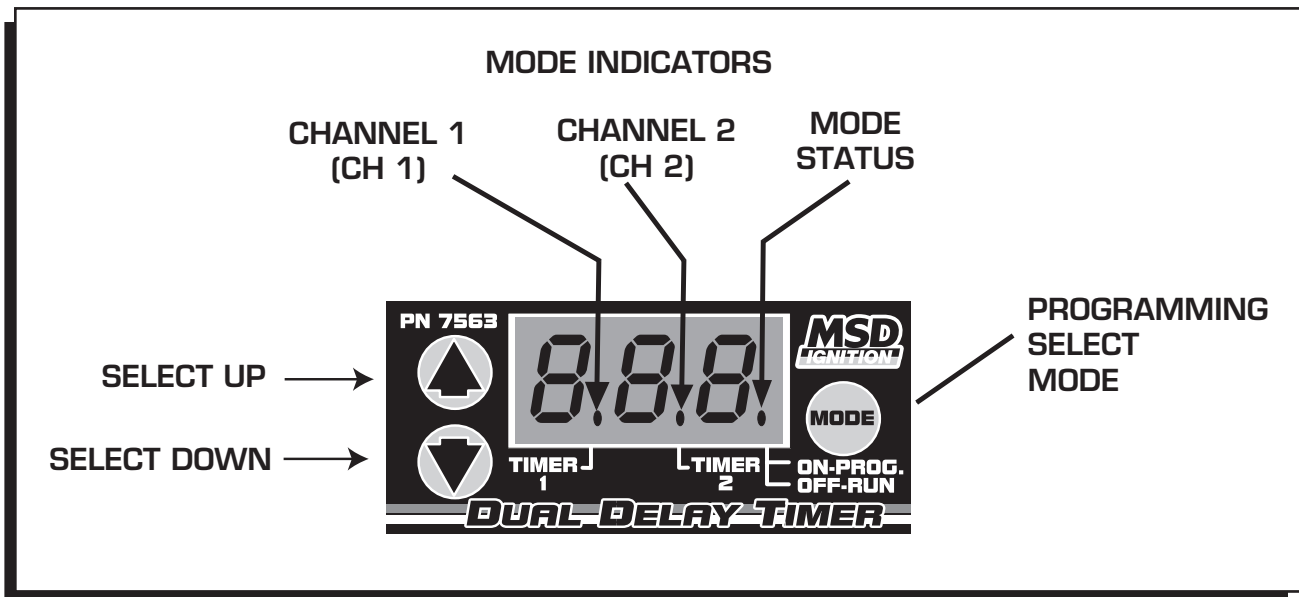

Figure 2 Read Out of the Dual Delay Timer.

Also notice the mode indicators on the monitor (Figure 2). Each of these LEDs will be illuminated while being programmed. Also, the LED will either be On when the Channel is activated or Off when the Channel is Off.

Once programmed, the Light Blue wire must be momentarily connected to 12 volts. This resets the Timer to zero. When 12 volts are removed from the Dark Blue wire, the timer begins. It will count to 9.99 seconds and stop. Note that the only way to stop the timer once it is going is to apply 12 volts to the Light Blue wire again (reset), or by touching any of the programming buttons.

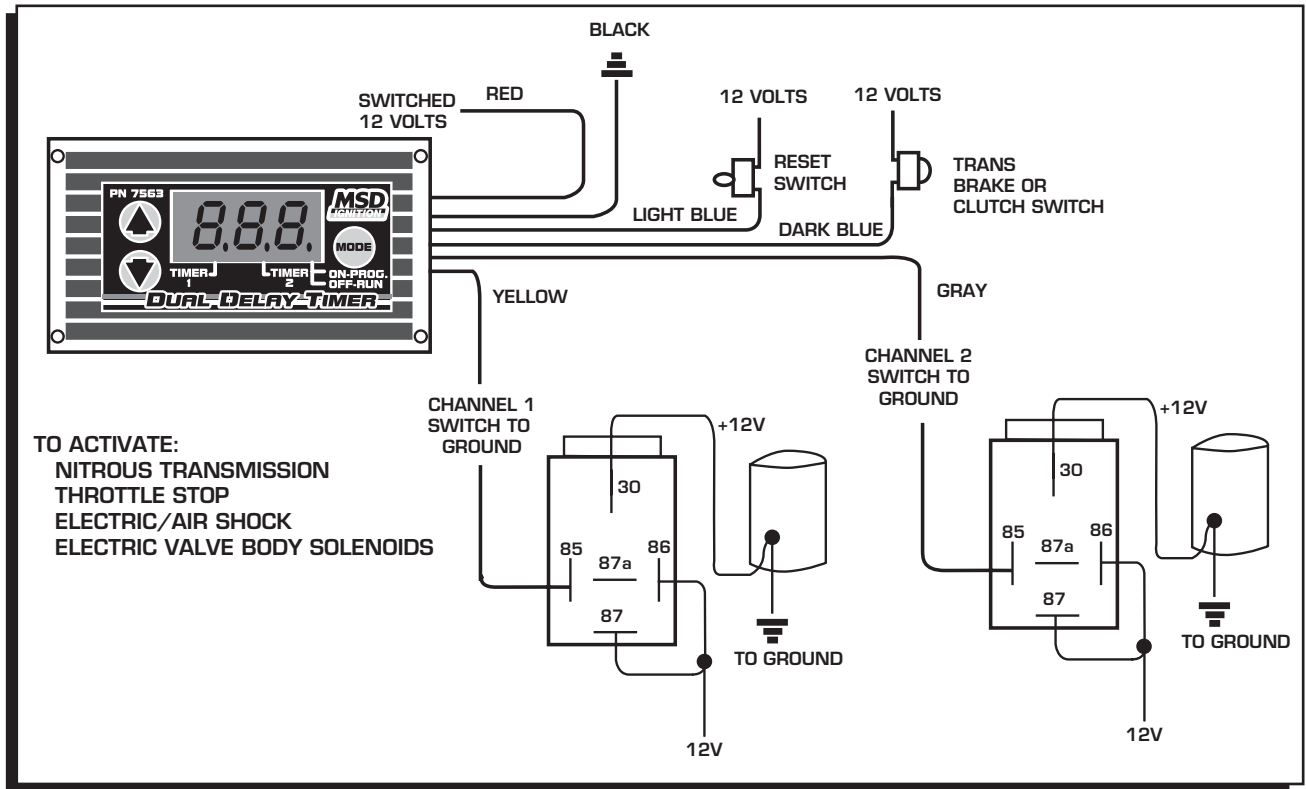

Figure 3 Wiring High Current Applications Switching to +12V.

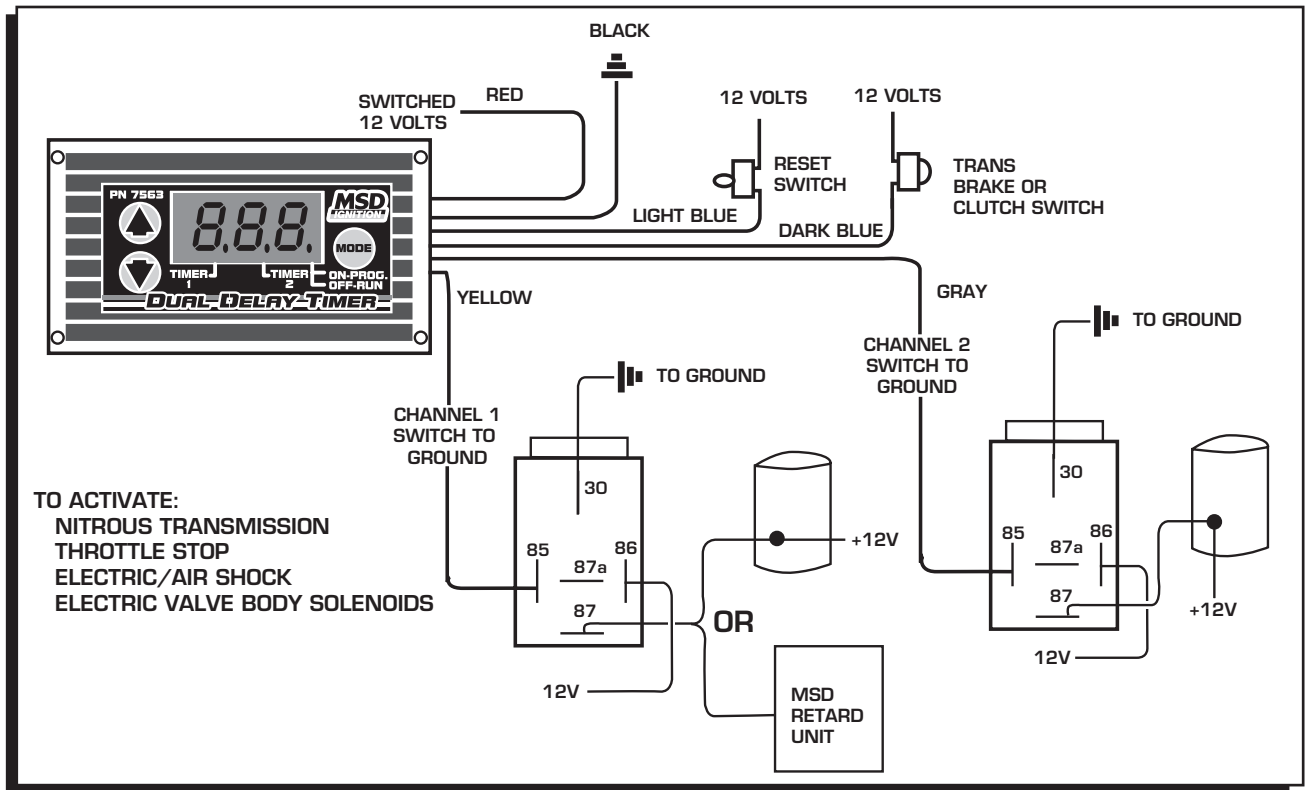

Figure 4 Wiring High Current Applications Switching to Ground.



INSTALLATION INSTRUCTIONS

TECH NOTES

Service

In case of malfunction, this MSD component will be repaired free of charge according to the terms of the warranty. When returning MSD components for service, Proof of Purchase must be supplied for warranty verification. After the warranty period has expired, repair service is charged based on a minimum and maximum charge.

All returns must have a Return Material Authorization (RMA) number issued to them before being returned. To obtain an RMA number please contact MSD Customer Service at (915) 855-7123 or fax a request to (915) 857-3344. Send the unit prepaid with proof of purchase to the attention of: **MSD Ignition, Customer Service - RMA #, 12120 Esther Lama, Dock 5, El Paso, Texas 79936.**

When returning the unit for repair, leave all wires at the length in which you have them installed. Be sure to include a detailed account of any problems experienced, and what components and accessories are installed on the vehicle.

The repaired unit will be returned as soon as possible after receipt, COD for any charges. (Ground shipping is covered by warranty). All units are returned regular UPS unless otherwise noted. For more information, call the MSD Customer Service Line (915) 855-7123. MSD technicians are available from 7:00 a.m. to 6:00 p.m. Monday - Friday (mountain time).

Limited Warranty

MSD IGNITION warrants MSD Ignition products to be free from defects in material and workmanship under normal use and if properly installed for a period of one year from date of purchase. If found to be defective as mentioned above, it will be replaced or repaired if returned prepaid along with proof of date of purchase. This shall constitute the sole remedy of the purchaser and the sole liability of MSD Ignition. To the extent permitted by law, the foregoing is exclusive and in lieu of all other warranties or representations whether expressed or implied, including any implied warranty of merchantability or fitness. In no event shall MSD Ignition be liable for special or consequential damages.