

A Holley Performance Brand

PROGRESSIVE NITROUS CONTROLLER P/N 15834NOS

A5164-SNOS

NOTICE: Installation of Nitrous Oxide Systems Inc. products signifies that you have read this document and have agreed to the terms stated within.

It is the purchaser's responsibility to follow all installation instruction guidelines and safety procedures supplied with the product as it is received by the purchaser to determine the compatibility of the product with the vehicle or the device the purchaser intends to install the product on.

Nitrous Oxide Systems Inc. assumes no responsibility for damages occurring from accident, misuse, abuse, improper installation, improper operation, lack of reasonable care, or all previously stated reasons resulting from incompatibility with other manufacturers' products.

Nitrous Oxide Systems Inc. assumes no responsibility or liability for damages incurred by the use of products manufactured or sold by Nitrous Oxide Systems Inc. on vehicles used for competition or racing.

Nitrous Oxide Systems Inc. neither recommends nor condones the use of products manufactured or sold by Nitrous Oxide Systems Inc. on vehicles, which may be driven on public roads or highways, and assumes no responsibility for damages incurred by such use.

It is the purchaser's responsibility to check the state and local laws pertaining to the use of Nitrous Oxide for racing applications. Nitrous Oxide Inc. does not recommend nor condone the use of its products for illegal street racing.

WARRANTY

Nitrous Oxide Systems Inc. warrants to the original purchaser that the Progressive Nitrous Controller shall be free from defects in parts and workmanship under normal use for 90 days from the date of purchase.

Nitrous Oxide Systems Inc.'s obligation under this warranty is limited to the repair or replacement of any component found to be defective when returned to the place of purchase. The Controller must be returned with a receipt proving the place and date of purchase or the warranty will be void.

The warranty will not apply if the Progressive Nitrous Controller has been installed incorrectly, repaired, damaged, or tampered with by misuse, negligence, or accident.

The installation of Nitrous Oxide Systems Inc. products signifies that you have read this document and have agreed to the terms stated within.

CAUTION

- Follow all recommended safety guidelines from this and other manufacturer's installation guides. Never install any device that pulsates nitrous solenoids without a safety solenoid installed.**
- Do NOT attempt to remove the cover from the Progressive Nitrous Controller. Damage to the unit will result and the warranty will be voided.**
- Static suppression ignition wires must be used with this unit!**
- Mount the unit as far away from the secondary ignition components (coil, ignition wires, etc.) as physically possible.**

DESCRIPTION

The Nitrous Oxide Systems Inc. Progressive Nitrous Controller utilizes a digital micro-controller for precise timing and control over the injection of nitrous oxide. Because the unit contains a micro-controller, static suppression ignition wires are required.

The rate of nitrous injection is programmable for beginning and final power percentages. The unit also contains a built-in digital delay timer allowing precise control of the starting time of the nitrous injection. The controller has the advanced feature of the ability to select the pulse frequency, in which the nitrous and fuel solenoids operate.

INSTALLATION:

WARNING: All diodes, capacitors, and filters from previous NOS installations must be removed! Failure to do so will result in undesirable operation of this unit.

WIRING TERMINAL DESCRIPTIONS:

1. Activate—The +12 volt input activates the progressive unit.
2. GND—Connect to the engine ground.
3. +12 volt—Connect to the +12 volts switched power.
4. +12 volt activation output—Supplies +12 volts at .25 amp.
5. NOS solenoid—Connect to the NOS solenoids ground wire. (This box controls the ground side of the solenoids.)

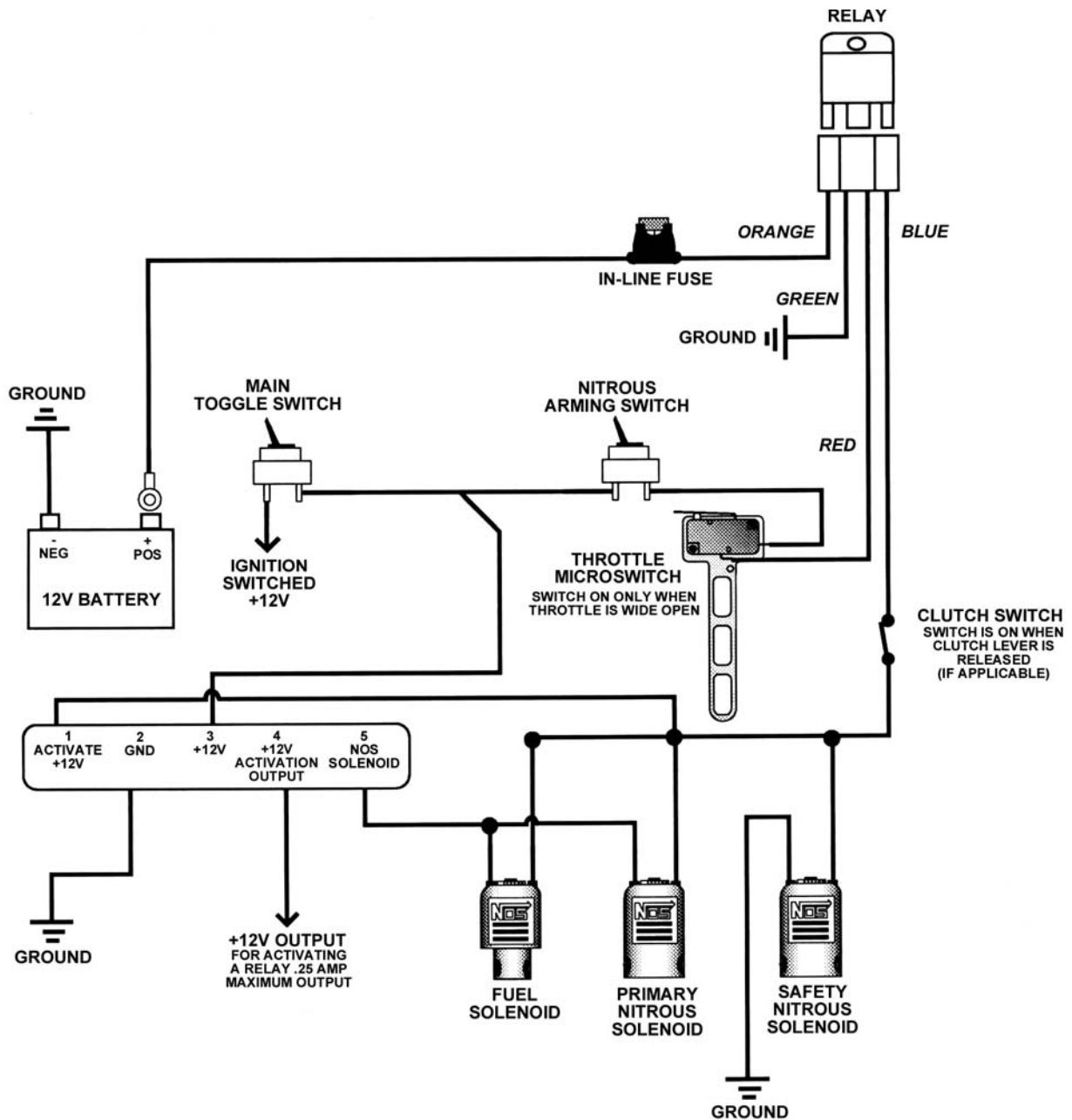

PROGRAMMING THE PROGRESSIVE NITROUS CONTROLLER:

To view the selected data, press the Program Switch momentarily.

NOTE: You must press and hold the Programming switch for 5 seconds when entering data.

➤ **Setting the +12 volt Activation Output Delay Time**

(This can be used to control a relay for a second stage.)

Place the Select Switch in the Activation Output Delay position. Set the desired delay time in seconds, using the data switches.

Example: [1 = 2, .1 = 5, .01 = 2, .001 = 0] = 2.520 seconds

Press the Programming Switch to enter your selection.

➤ **Setting the Display Brightness**

Place the Select Switch at the Display Brightness position. Using the .001 Data Switch select the desired level (0 to 6). Press the Programming Switch to enter your selection.

➤ **Setting the NOS Pulse Frequency**

Place the Select Switch at the NOS Pulse Frequency position. Using the .001 Data Switch, select the desired frequency.

Example: [0 = 20, 1 = 25, 2 = 30, 3 = 35, 4 = 40]

Press the Programming Switch to enter your selection.

NOTE: The Pulse Frequency = how many times per second the solenoids operate. The higher the frequency, the more pulses per second. All production NOS solenoids operate best at 25 – 30 Hz.

➤ **Run Position**

It is recommended that the Select Switch is in the Run position for normal operation. However, the unit will operate in all Select Switch positions.

➤ **Setting the Timer Delay**

(Amount of Delay before Progressive starts)

Place the Select Switch in the Timer Delay position. Set the desired Delay Time in seconds, using the Data Switches.

Example: [1 = 2, .1 = 5, .01 = 2, .001 = 0] = 2.520 seconds

Press the Programming Switch to enter your selection.

➤ **Setting the NOS Start Percent**

Place the Select Switch in the Start Percent position. Set the desired NOS Starting Percent, using the Data Switches.

Example: [.1 = 0, .01 = 2, .001 = 1] = 21%

NOTE: Data Switch 1 is ignored for this setting. Valid percentages are from 20% to 100%. Press the Programming Switch to enter your selection.

➤ **Setting the NOS Build Time**

Place the Select Switch in the Build Time position. Set the Build Time, using the Data Switches.

Example: [1 = 3, 1 = 5] = 3.5 seconds

NOTE: Data Switches .01 and .001 are ignored for this setting. Valid Build Time in seconds is from .2 to 9.9 seconds. Press the Programming Switch to enter your selection.

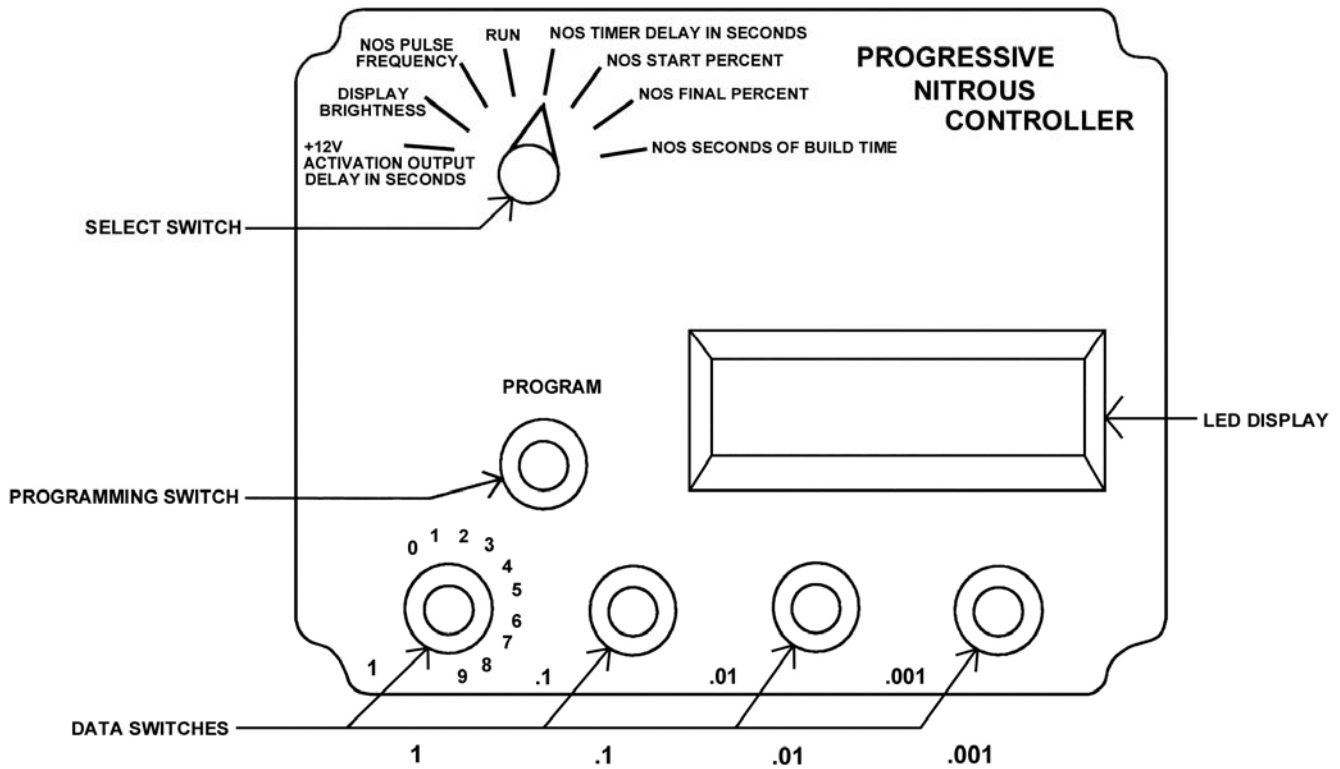

DISPLAY MESSAGES:

Program When this message appears on the display, it indicates that valid data was programmed and is now stored in memory.

Invalid When this message appears on the display, it indicates that the data was not valid and it was not stored in memory.

NOS Technical Service

Phone: 1-866-GOHOLLEY

Fax: 1-270-781-9772

For online help, please refer to the Tech Service section of our website: www.holley.com