

SCHNITZ

Racing

1.800.837.9730
www.schnitzracing.com

Schnitz Motorsports

Performance at its Best!

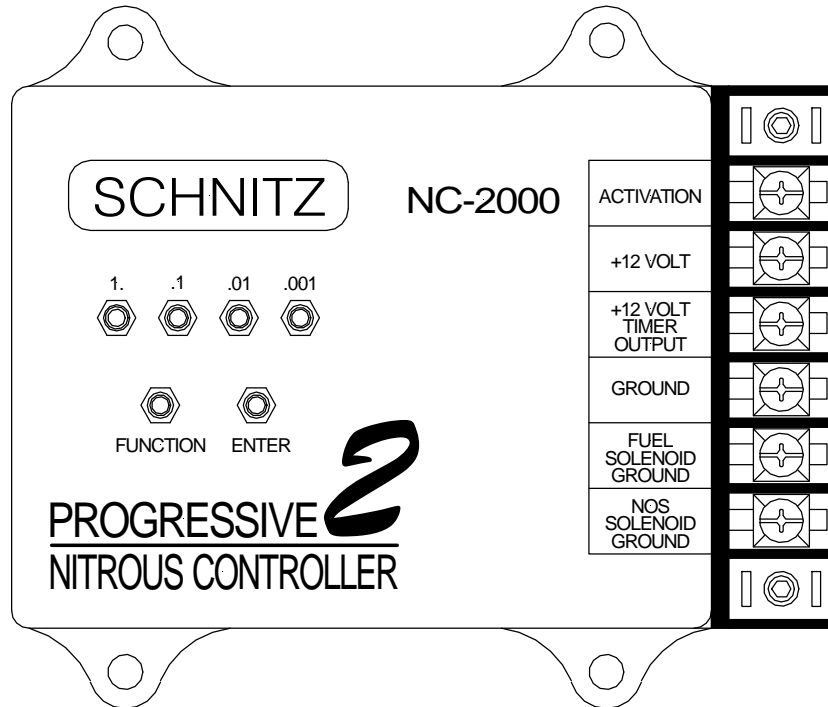

Nitrous Power Control

NC-2000

Installation & and User Guide

Important Information - Must use Static Suppression Ignition Wires with this Controller. The NC-2000 Nitrous Controller contains High Frequency Digital Electronics and will NOT function correctly without Suppression Wires!

Caution - Do NOT submerge Controller in liquid or directly wash unit with liquid of any type!

Warning - The Programming Switches are Delicate Electronic items and can be damaged by misuse and/or carelessness. If the Controller is close to your NOS Bottle be careful when installing the bottle. The weight of the bottle is enough to easily damage the switches. Switches that have been determined to be damaged due to neglect will NOT be covered under Warranty.

Notice:

Copyright (c) 2001 Schnitz Motorsports, Decatur, Indiana. All rights reserved. This document is protected by copyright law. It is unlawful to make copies, modify, or distribute without written consent from Schnitz Motorsports.

It is the responsibility of the purchaser to follow all guidelines and safety procedures supplied with this product and any other manufactures product used with this product. It is also the responsibility of the purchaser to determine compatibility of this device with the vehicle and other components.

Schnitz Motorsports assumes no responsibility for damages resulting from accident, improper installation, misuse, abuse, improper operation, lack of reasonable care, or all previously stated reasons due to incompatibility with other manufacturer's products.

Schnitz Motorsports assumes no responsibility or liability for damages incurred from the use of products manufactured or sold by Schnitz Motorsports on vehicles used for competition racing.

Schnitz Motorsports neither recommends nor approves the use of products manufactured or sold by Schnitz Motorsports on vehicles which may be driven on public highways or roads, and assumes no responsibility for damages incurred from such use.

It is the purchasers responsibility to check the state and local laws pertaining to the use of Nitrous Oxide for racing applications. Schnitz Motorsports does not recommend nor condone the use of its products for illegal street racing.

Installation of Schnitz Motorsports products signifies that you have read this document and agree to the terms stated within.

Caution:

Follow all recommended safety guidelines from this and other manufactures installation guides.

Never install any device which pulsates nitrous solenoids without a safety solenoid installed.

Static suppression ignition wires must be used with this unit! Mount the unit as far away from secondary ignition components(coil, ignition wires, etc.) as physically possible.

NC-2000, Progressive Nitrous Controller

The NC-2000 Progressive Nitrous Controller was designed using the latest Digital Technology available. The result is a Controller which is extremely accurate and user friendly. A simple and functional programming interface allows the user to set important Nitrous parameters in a matter of seconds. All without the use of external programmers or computers. An Options Menu has been included to enable the User to Customize the Controller for a particular application. The Options Menu also contains a function that if selected will return the controller to its Original Factory Pre-Programmed State.

Features

Full Digital Circuitry, This design approach assures the best in performance and reliability. Digital Technology provides extremely accurate control that cannot be achieved with Analog Systems.

Easy to Read LED Display with Touch Switch programming. This user interface is very user friendly and provides Quick and Accurate Programming of the controller.

Integrated Battery Voltage Monitor, The battery voltage is displayed periodically on the LED Display.

Non-Volatile Data Memory, No battery or power connection is needed to retain the controllers parameter settings. There is no need to re-program the controller after the battery is disconnected. There is NO internal battery, all Data is stored in Flash Memory and will be retained for up to 10 years with no power applied to the controller.

Separate Nitrous and Fuel Solenoid Outputs, This design provides more output current capability. By using separate outputs better control of the solenoids is achieved. The response of the Nitrous System is improved and much more accurate. The Fuel Output is Programmed to Function as though the Fuel and Nitrous Solenoids were on the Same Output Terminal. The Options Menu allows the User to Program the Fuel Solenoid Output to Operate in Full Progressive Mode (i.e. - The fuel solenoid will pulse through the entire progression).

+12 Volt Timer Output, A digital timer is provided that can be used to Activate an Ignition Retard Controller or a 2nd Stage of Nitrous. The output from this timer provides +12 volts at 1 amp. This timer begins counting down when the Activation Terminal is on(+12v applied). If the Activation signal is removed the +12V Timer will halt until the signal is reapplied. The +12V Timer can be programmed from 0.000 to 9.999 seconds. The Options Menu allows the User to configure the Timer Output behavior while the Controller is in the Activated State. Optionally the Output can be configured to Remain ON regardless of the Activation Input. NOTE—Setting Timer to 0.000 will disable the Timer Output.

Nitrous Delay Timer, A digital timer is provided that can be used to delay the start of the Nitrous. This timer begins counting down when the Activation Terminal is on(+12v applied). If the Activation signal is removed the Delay Timer will halt until the signal is reapplied. The Delay Timer can be programmed from 0.000 to 9.999 seconds.

Nitrous Starting Percentage, The user can program the amount of Nitrous Power that will be applied after the Nitrous Delay Timer has elapsed(Immediately if Delay Timer is set at 0.000). This parameter is set as a percentage and can range from 10% to 100%. If the Starting Power is more than the Ending Power the Nitrous Power will decrease with time.

Final Nitrous Percentage, This setting allows the user to program how much Nitrous Power is applied after the Nitrous Power Ramp has completed. This parameter is also set as a percentage and can range from 10% to 100%. By setting the Final Power Percentage less than the Starting Percentage the user can back off the Nitrous Power.

The Options Menu allows the User to select a Single or Dual Ramp Nitrous Power Ramp. When the Dual Ramp Mode is selected there will be 2 Final Percents and 2 Power Ramp Times.

Nitrous Power Ramp Time, The Power Ramp Time is used to determine the rate at which the Nitrous Power goes from the Start Percentage to the Final Percentage. The Nitrous Power Ramp time can be set from .200 to 9.900 seconds.

The Options Menu allows the User to select a Single or Dual Ramp Nitrous Power Ramp. When the Dual Ramp Mode is selected there will be 2 Final Percents and 2 Power Ramp Times.

Intelligent Nitrous Progressive Timer, The Progressive Nitrous timer system will wait at its present state if the Activation signal is removed. Nitrous progression will resume when the controller is re-activated. The entire Nitrous and +12 Volt Timer System is automatically Reset 20 seconds after activation.

Optionally the Nitrous Timer System can be configured to RESET each time the Activation Signal is Applied. This method would allow the Nitrous Power to be applied with each gear change or each time the throttle is lifted and re-applied. This feature is selected with the Options Menu.

An added feature has been added to the Timer System to help the User Tune the Nitrous Power Ramp. When the Timer System is Activated(+12V at the Activation Input) an Internal Timer is started which will record the Time and Percent of the Progressive Cycle when the Activation Signal is Removed. This Data can be used to determine at what point in the Progressive Cycle that the Power Ramp is too Aggressive and the driver is lifting the throttle.

Table of Contents

Programming

+12 Volt Timer	Page 6
Nitrous Delay Timer	Page 6
Nitrous Starting Percentage	Page 7
Nitrous Ending Percentage	Page 7
Nitrous Power Ramp Time	Page 8
Example Nitrous Power Setting	Page 8

Options Menu, Programming

Viewing Run Data and Entering the Options Menu	Page 9
Clearing Run Data(Reset for next run)	Page 9
Resetting Controller to Factory Defaults	Page 9
Calibrating the Voltage Monitor	Page 9
Setting the Dual Nitrous Power Ramp ON/OFF	Page 10
Setting Progressive Fuel Output ON/OFF	Page 10
Setting Activation Wait and Hold ON/OFF	Page 10
Setting +12V Timer Output Hold ON/OFF	Page 11
Enabling Quick Data Access	Page 11
Setting the RESET Timeout Period	Page 11
Exiting the Options Menu	Page 11

Using the Dual Ramp Feature

How the Dual Power Ramp Functions	Page 12
Example Dual Ramp Nitrous Power Setting	Page 12

Installation

Items Included with NC-2000 Controller	Page 13
Items needed that are NOT Supplied	Page 13
Cautions and Warnings	Page 13
Wiring Diagram	Page 14

Technical Information

Electrical Specifications	Page 15
Trouble Shooting	Page 15
Warranty	Page 16

Programming the +12 Volt Timer

Press and Release the FUNCTION Switch until the message "+12V Timer Delay" appears on the display. After the Function Message has scrolled across the display the Current +12 Volt Timer setting will appear on the display.

To adjust the +12 Volt Timer Value press the desired Digit Button and the Value of that digit will increment. The digit will Roll over to 0 and begin counting up again if the user continues to release and press the Digit Button.

To Exit without saving the New Value press the FUNCTION Switch and Select another Function.

To Save the New Value press and release the ENTER Switch and the display will read "SAVED" and the new setting is now saved.

Range of +12 Volt Timer is 0.000 to 9.999 seconds with a .001 second resolution.

This setting will determine the amount of Time in Seconds before the +12 Volt Timer Output becomes Active(goes to +12V) after Controller Activation.

NOTE—Setting Timer to 0.000 will Disable the +12V Timer Output. Set to 0.001 for quick activation.

Programming the Nitrous Delay Timer

Press and Release the FUNCTION Switch until the message "NOS Delay Timer" appears on the display. After the Function Message has scrolled across the display the Current Nitrous Delay Time setting will appear on the display.

To adjust the Nitrous Delay Timer Value press the desired Digit Button and the Value of that digit will increment. The digit will Roll over to 0 and begin counting up again if the user continues to release and press the Digit Button.

To Exit without saving the New Value press the FUNCTION Switch and Select another Function.

To Save the New Value press and release the ENTER Switch and the display will read "SAVED" and the new setting is now saved.

Range of Nitrous Delay Timer is 0.000 to 9.999 seconds with a .001 second resolution.

This setting will determine the amount of Time in Seconds before the Nitrous becomes Active(Nitrous begins at Starting Percentage) after Controller Activation.

Programming the Nitrous Starting Percentage

Press and Release the FUNCTION Switch until the message "Starting Percentage" appears on the display. After the Function Message has scrolled across the display the Current Nitrous Starting Percentage setting will appear on the display.

To adjust the Nitrous Starting Percentage Value press the desired Digit Button and the Value of that digit will increment. The digit will Roll over to 0 and begin counting up again if the user continues to release and press the Digit Button. If the .1 Digit Button is pressed the Starting Percentage will go to 100%, pressing again will set the Starting Percentage back to 0%. The 1. Digit is ignored for this function.

To Exit without saving the New Value press the FUNCTION Switch and Select another Function.

To Save the New Value press and release the ENTER Switch and the display will read "SAVED" and the new setting is now saved.

Range of Nitrous Starting Percentage is 10 to 100 percent in 1% increments.

This setting will determine the amount of Nitrous to be applied after the Nitrous Delay Timer has elapsed.

Programming the Final Nitrous Percentage

Note - If the Dual Ramp Feature is Enabled from the Options Menu there will be a "Final Percent #2" in the Menu List. The Programming Method is the same as the "Final Percent #1". Please Refer to the section Options Menu and Using the Dual Ramp Feature for more information.

Press and Release the FUNCTION Switch until the message "Final Percent #1" appears on the display. After the Function Message has scrolled across the display the Current Final Nitrous Percentage setting will appear on the display.

To adjust the Final Nitrous Percentage Value press the desired Digit Button and the Value of that digit will increment. The digit will Roll over to 0 and begin counting up again if the user continues to release and press the Digit Button. If the .1 Digit Button is pressed the Final Percentage will go to 100%, pressing again will set the Final Percentage back to 0%. The 1. Digit is ignored for this function.

To Exit without saving the New Value press the FUNCTION Switch and Select another Function.

To Save the New Value press and release the ENTER Switch and the display will read "SAVED" and the new setting is now saved.

Range of Final Nitrous Percentage is 10 to 100 percent in 1% increments.

This setting will determine the amount of Nitrous to be applied at the end of the Nitrous Power Ramp Time.

Programming the Nitrous Power Ramp Time

Note - If the Dual Ramp Feature is Enabled from the Options Menu there will be a "NOS Build Time #2" in the Menu List. The Programming Method is the same as the "Build Time #1". Please Refer to the section "Options Menu" and "Using the Dual Ramp Feature" for more information.

Press and Release the FUNCTION Switch until the message "NOS Build Time #1" appears on the display. After the Function Message has scrolled across the display the Current Nitrous Power Ramp Time setting will appear on the display.

To adjust the NOS Build Time press the desired Digit Button and the Value of that digit will increment. The digit will Roll over to 0 and begin counting up again if the user continues to release and press the Digit Button. The .01 and .001 Digit is ignored for this function.

To Exit without saving the New Value press the FUNCTION Switch and Select another Function.

To Save the New Value press and release the ENTER Switch and the display will read "SAVED" and the new setting is now saved.

Range of NOS Build Time is .200 to 9.900 seconds in .1 second increments.

This setting will determine the Rate at which the Nitrous Power goes from Starting to Final Percent. A short Power Ramp Time will make the Nitrous power very aggressive and a long Power Ramp Time will make the Nitrous Power less aggressive.

Example Nitrous Power Setting, Dual Ramp Feature OFF

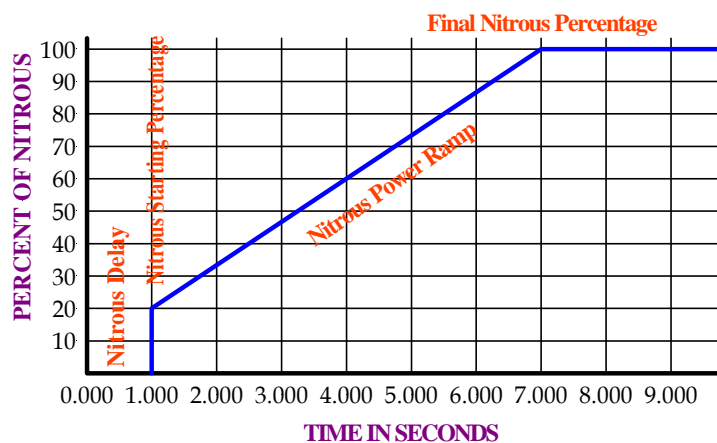

Nitrous Delay Timer = 1.000 seconds

Nitrous Starting Percentage = 20%

Final Nitrous Percentage = 100%

Nitrous Power Ramp Time = 6.000 seconds

Viewing Run Data and Entering the Options Menu

Press and Release the FUNCTION Switch until the message "Progressive 2 Nitrous Controller, NC-2000" appears on the display.

Press and HOLD the ENTER Switch the display will show the Time at which the Activation Input was turned OFF for the Previous Progressive Cycle. After 5 seconds the display will show the NOS Percent at which the Activation Input was turned OFF for the Previous Progressive Cycle.

The controller will only Save the 1st occurrence after Activation and Only if the Run Data has been Cleared(This procedure is outlined below).

Continue to hold the ENTER Switch until the display reads "RELEASE". At this time the Controller has entered the Options Menu. Please refer to the following instructions regarding the Selections Available here.

Note - You may Release the ENTER Switch before entering the Options Menu and return to the Main Menu.

Clearing Run Data(Reset for next run)

Enter the Options Menu, "Clear Run Data" is the first Option.

Pressing ENTER will Erase the current Run Data and then return to the Main Menu.

Pressing FUNCTION will select the next Option available.

Resetting Controller to Factory Defaults

Enter the Options Menu, Press and Release the FUNCTION Switch until the message "Reset Factory Default Settings" appears on the Display.

Pressing ENTER will Restore the Controller to the Factory Default Settings and then return to the Main Menu.

Pressing FUNCTION will select the next Option available.

Calibrating the Voltage Monitor

Enter the Options Menu, Press and Release the FUNCTION Switch until the message "Calibrate Voltage Monitor" appears on the Display.

Using a Volt Meter compare the Volt Reading on the Display to the Volt Meter Reading. Press and Release the ENTER Switch to adjust the Reading until it is correct.

Refer to "Exiting the Options Menu" to Return to the Main Menu.

Pressing FUNCTION will select the next Option available.

Setting the Dual Nitrous Power Ramp ON/OFF

Enter the Options Menu, Press and Release the FUNCTION Switch until the message "DUAL RAMP Nitrous" appears on the Display.

Press and release the ENTER Switch to turn this feature ON or OFF. After pressing the ENTER Switch the Display will show the New State of the Selected Option. Refer to "Exiting the Options Menu" to Return to the Main Menu.

If this Option is ON(Factory Default is OFF) two more selections will appear on the Main Menu. Please refer to the Section "Using the Dual Ramp Feature" for more information.

Setting Progressive Fuel Output ON/OFF

Enter the Options Menu, Press and Release the FUNCTION Switch until the message "Progressive Fuel Solenoid Driver" appears on the Display.

Press and release the ENTER Switch to turn this feature ON or OFF. After pressing the ENTER Switch the Display will show the New State of the Selected Option. Refer to "Exiting the Options Menu" to Return to the Main Menu.

When this Option is ON the Fuel Output will Pulsate through the Entire Nitrous Progression Cycle. If this Option is OFF(Factory Default) then the Fuel Output will Pulsate for the First 5 Pulses and then go to 100%.

Setting Activation Wait and Hold ON/OFF

Enter the Options Menu, Press and Release the FUNCTION Switch until the message "Reset Wait and Hold" appears on the Display.

Press and release the ENTER Switch to turn this feature ON or OFF. After pressing the ENTER Switch the Display will show the New State of the Selected Option. Refer to "Exiting the Options Menu" to Return to the Main Menu.

When this Option is ON(Factory Default) All Timers, including the Progressive Timers will Halt if the Activation Signal(+12V) is removed and will Resume when the Signal is Re-Applied. If this Option is OFF All Timers will be Reset each time the Activation Signal (+12V) is removed(i.e. - Each time the Activation Signal is Applied the Controller Starts at the Beginning of the Timing Cycle).

Setting +12V Timer Output Hold ON/OFF

Enter the Options Menu, Press and Release the FUNCTION Switch until the message "+12V Timer Output Hold" appears on the Display.

Press and release the ENTER Switch to turn this feature ON or OFF. After pressing the ENTER Switch the Display will show the New State of the Selected Option. Refer to "Exiting the Options Menu" to Return to the Main Menu.

When this Option is OFF(Factory Default) the +12V Timer Output will Turn OFF each time the Activation Signal is Removed.

Enabling Quick Data Access

Enter the Options Menu, Press and Release the FUNCTION Switch until the message "Quick Data Access" appears on the Display.

Press and release the ENTER Switch to turn this feature ON or OFF. After pressing the ENTER Switch the Display will show the New State of the Selected Option. Refer to "Exiting the Options Menu" to Return to the Main Menu.

When this Option is ON(Factory Default is OFF) the Data will appear before the Text in the Main Menu. Those familiar with the Controller can Access or Check the Current Setup much more quickly.

Setting the RESET Timeout Period

Enter the Options Menu, Press and Release the FUNCTION Switch until the message "Timeout in Seconds" appears on the Display.

Press and release the ENTER Switch to Increase the Timeout Period in 10 second increments. If the Timeout Period is more than 180 seconds the controller will default back to 20 seconds. Refer to "Exiting the Options Menu" to Return to the Main Menu.

Note - If the Timeout Period is 100 seconds or more the Run Data Time will be recorded in .01 second resolution.

Exiting the Options Menu

Press and Release the FUNCTION Switch until the message "Exit Options Menu" appears on the Display.

Press and Release the ENTER Switch to return to the Main Menu.

Press and Release the FUNCTION Switch to return to the Top of the Options Menu.

How the Dual Power Ramp Functions

The Dual Nitrous Ramp feature enables the user to have more precise control over the Nitrous Power Ramp. When the Dual Ramp feature is enabled there are two more selections added to the Main Menu. These are "Final Percent #2" and "NOS Build Time #2". Using these extra set points the user can build a Power Ramp that is non-linear (i.e. - can be small power increase for 2 seconds and then ramp to full power very rapidly). Please view the example outlined below for help in determining the proper setup for your application.

Example Dual Ramp Nitrous Power Setting

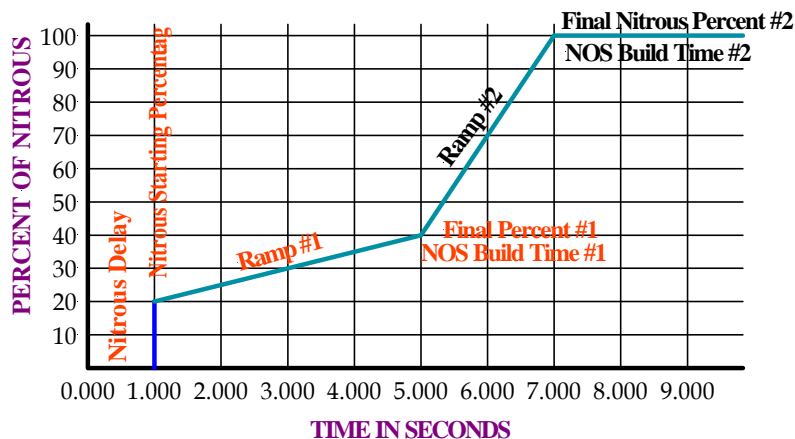

NOS Delay Timer = 1.000 seconds
Starting Percent = 20%
Final Nitrous Percent #1 = 40%
NOS Build Time #1 = 4.000 seconds
Final Nitrous Percent #2 = 100%
NOS Build Time #2 = 2.000 seconds

Items Included with the NC-2000 Controller

- 1 - Wiring Harness
- 2 - Nitrous Arming Switch
- 5 - Installation & User Manual

Items needed that are NOT Supplied with Controller

- 1 - Nitrous Kit, Use NOS Nitrous Kit for best Performance
- 2 - Safety Solenoid
- 3 - Activation Switches as needed, If they were not included with the Nitrous Kit.

Cautions and Warnings

- 1 - Always follow Installation Guidelines and Safety Pre-cautions when installing any other related components.
- 2 - Remove battery connections when installing new components and/or wiring.
- 3 - Always use proper Circuit Protection where required(Fuse).
- 4 - Always test system operation after installation to insure proper operation.
- 5 - Connect Ground wire Direct to Battery Negative Terminal and then to Controller.

IMPORTANT - Must use Static Suppression Ignition Wires. Can NOT use any type of Metal Spiral Core and/or Metal Core Ignition Wires. Controller contains High Frequency Digital Circuitry and can NOT function properly with RFI or EMI Interference!

Wiring Diagram

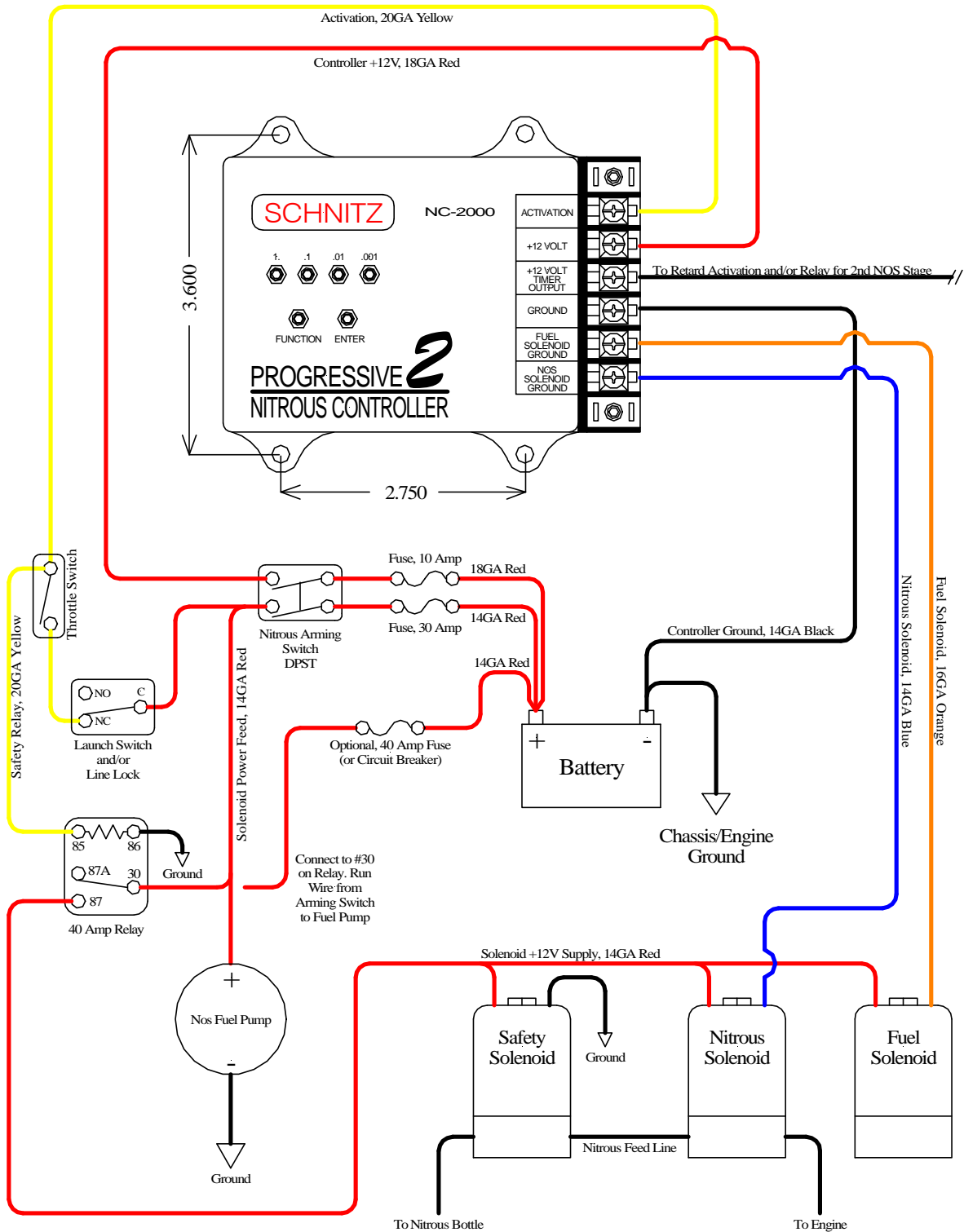

Electrical Specifications

Normal Operating Voltage	10.0 to 16.0 Volts, Negative Ground Controller will Turn OFF at 6.2 Volts
+12 Volt Timer Output	1 Amp Maximum
Nitrous Solenoid Ground	45 Amps Maximum
Fuel Solenoid Ground	45 Amps Maximum
Activation Input	.5mA at 12.0 Volts
Weight	.8 lb.
Overall Height	1.125 in.
Overall Width	4.000 in.
Overall Length	4.700 In.

Caution - Do NOT submerge Controller in liquid or directly wash unit with liquid of any type!

Trouble Shooting

1 - Engine Running Rich while using Progressive Nitrous

A - Starting Percentage to low for a given bottle pressure and solenoid combination(only fuel solenoid opening).

B - Fuel pressure to high for fuel solenoid to operate correctly when pulsating.

2 - Nitrous seems to Delay after Activation

A - Improper Nitrous Delay Timer setting.

B - Starting Percentage to low for a given bottle pressure and solenoid combination(only fuel solenoid opening).

3 - Nitrous Turns OFF during operation

A - To much current draw from solenoids.

B - Electrical interference from Ignition System or other Electronic Device(s).

Warranty

Schnitz Motorsports warrants to the original purchaser that the NC-2000 Controller shall be free from defects in parts and workmanship under normal use for 6 months from the date of purchase.

Schnitz Motorsports obligation under this warranty is limited to the repair or replacement of any component found to be defective when returned postpaid to Schnitz Motorsports. The Controller must be returned with evidence of place and date of purchase or warranty will be void. The warranty will not apply if the NC-2000 Controller has been installed incorrectly, repaired, damaged, or tampered with by misuse, negligence or accident.

Phone 1-219-728-9457