



INSTALLATION INSTRUCTIONS

1917 Oak Park Blvd. • Pleasant Hill, CA 94523
(925)935-3025 • Fax (925)935-2287

Reaction Time
Delay
Model RTD-7

INSTALLATION

- 1) Mount the Reaction Time Delay unit away from heat, vibration & ignition wires. Fasten it with (4) #6 sheet metal screws, slightly compressing the rubber mounting grommets. It can be mounted in any position, even upside down for overhead locations.
- 2) Wire the unit as shown in the wiring diagram. Use at least 14 gauge wire or larger. Install a fuse or circuit breaker to protect the box from possible damage. Make sure you have a good ground connection. (Grounding to the aluminum interior sheet metal is not reliable.) The "SAFETY SWITCH" (Bypass Switch) is supplied by Dedenbear. The RTD-7 has been specifically designed to operate at voltages up to 18 volts. You can now wire your unit directly to the 16 volt terminal if you are using a 16 VOLT BATTERY. Do not power the RTD-7 and ignition with the same wire or battery cable, instead, run a separate 12 ga. power wire from the master "cut-off" switch at the back of the car directly to the RTD-7.
- 3) The line lock terminal allows you to lock the front wheel brakes without back-feeding and locking the trans brake during burn-outs. **If you don't want to connect the line-lock to your RTD, simply don't wire the "Line Lock" terminal.
- 4) As a safety device, the Reaction Time Delay has a circuit that cuts off power to the unit once the transbrake has been released. FOR ADDED SAFETY, THE SAFETY (Bypass) SWITCH SHOULD BE SET ON "NO DELAY" ANYTIME THAT THE CAR IS NOT ON THE RACETRACK. The safety switch completely bypasses the reaction time delay box so it can also be used as a backup switch in case you choose not to use the delay box. ** It selects either your button or the delay box to power the transbrake solenoid.
- 5) The safety switch also allows you to "bump" the car into the lights with the trans brake during staging, and "pro-brake" valve body transmissions can backup the vehicle in reverse. This means you won't have to wait for the delay to release each time you release the trans brake switch.

** NOTE: Safety switch only controls the "Transbrake" terminal. The "Line Lock" terminal (if used) will always delay whatever amount delay is programmed into the RTD.

SEE REVERSE SIDE FOR WIRING DIAGRAMS

OPERATION

- 1) Set the pushbutton thumbwheels to the desired delay setting.
- 2) Use your line lock button to do your burnout (if used).
- 3) If you need to engage the transbrake to back-up the car, do so with the safety switch set to "No Delay".
- 4) If you have a long delay dialed in and you stage by using the trans brake, then set the safety switch to "No Delay" and "bump" the car into the lights. After you are staged, hold the trans brake switch and flip the safety switch to "Delay". If you have a short delay setting, just use the trans brake switch to stage the car.
- 5) When the Christmas tree light that you are leaving off of turns on, release the trans brake switch. After the dialed in delay time, the trans brake will release and launch the car.
- 6) ALWAYS SET THE SAFETY SWITCH TO "NO DELAY" WHENEVER THE CAR IS NOT ON THE TRACK READY TO MAKE IT'S RUN, OR WHEN BACKING UP THE CAR WITH "PRO" BRAKE VALVEBODIES.

TIPS ON SETTING THE DELAY

If you run on a Full tree, the time between lights is .500 seconds. Therefore, a perfect light is 500 (a Pro tree is .400) If you have a 472 light on a Full tree, leaving off the last amber, you need to set the time to 0028 ($500-472=28$ thousandths), or 1.028 if you leave off the top amber (1.028 seconds). If your competitor is slower than yours & you leave off his top light, then add the handicap amount to your setting - i.e.: if his dial-in is 12.00 & yours is 11.00, then your delay setting should be 2.028 in the above example ($1.028 + 1.000$ second handicap). We recommend adding .010 or .020 seconds as a cushion in case you stage deeper than normal. For a night race, add extra time because you see the lights turn on sooner than in the daytime.

WARRANTY

Dedenbear Products components are warranted directly by Dedenbear Products against defective material or workmanship under normal use and service for a period of **one (1) year** after purchase. Dedenbear Products will repair or replace the defective unit, at Dedenbear Products option, free of charge. This warranty does not cover any damage to the component caused by abuse, mishandling, alteration, electrical current fluctuations, failure to follow installation/operating instructions, maintenance, storage and environmental conditions, or repair attempts made by anyone other than Dedenbear Products Authorized Service facility.

DEDENBEAR PRODUCTS SHALL NOT BE LIABLE FOR INJURY, CONSEQUENTIAL, OR OTHER TYPE DAMAGES RESULTING FROM THE USE OF ITS PRODUCTS, OTHER THAN THE LIABILITY STATED ABOVE. This warranty is in lieu of all other warranties of merchantability or fitness of use. This warrant gives you specific legal rights, and you may also have other rights which vary from state to state.

FOR SERVICE on all Dedenbear Products, return directly to: DEDENBEAR PRODUCTS, INC. • ATTN: REPAIRS • 1917 OAK PARK BLVD. • PLEASANT HILL, CA 94523. For faster service, please include a note describing the nature of the problem, a copy of your original invoice, your name, return shipping address, and daytime phone number where you can be reached.

For Tech. Assistance, Call: (925)935-3025

Rev. 3/98

RTD-7 • DELAY BOX INSTALLATION

In this installation, the trans-brake will be delayed only when the "Safety Switch" (Bypass switch) is in the "Delay" mode. This can be checked with a test light on the center of the toggle switch. Please set the switch to "No Delay" at all times except when you are on the track and staging. **THE SAFETY SWITCH PROVIDES ABSOLUTE 0.000 SECONDS DELAY!** It selects whether YOUR BUTTON or the DELAY BOX is supplying all the power to the Transbrake solenoid.

*Warning: The optional Line-Loc terminal will always have whatever delay is set on the delay box! Please install a fuse or circuit breaker (15-20amp) in the +12v wire to protect the delay box from expensive damage if your transbrake solenoid fails or ever shorts out. Wire the box with at least 14 gauge wire. The +12v power wire should be at least 12 gauge, and should be direct to the Master ON-OFF switch at the back of the car. Model RTD-7 is designed to work on all +12v & +16v batteries.

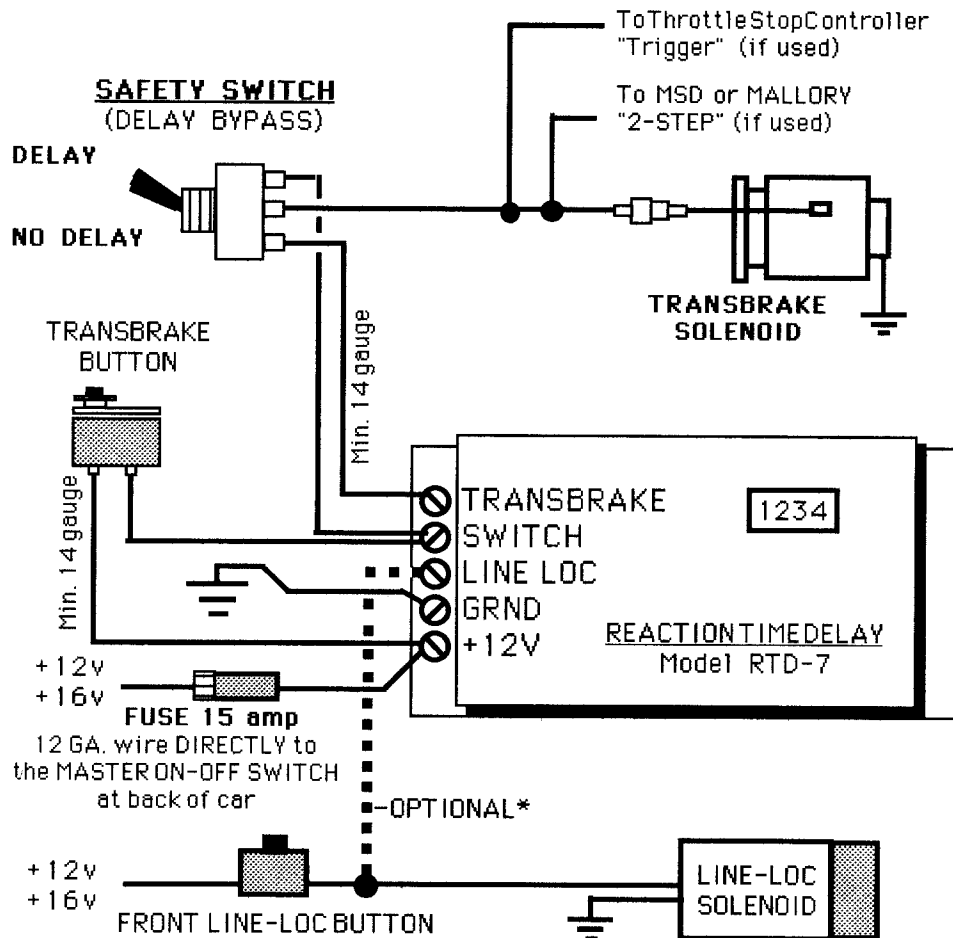

RTD-7 • DUAL LINE-LOC INSTALLATION

In this application, two buttons are needed to control the dual line-loc solenoid. One button will be used for the burn-out and lock only the front brakes. The second button is used for the launch and will lock both front & rear brakes; also go through the delay box. The main +12v wire should also come off the master on-off switch at the back of the car using at least a 12-gauge wire. Again, protect the box with a fuse or circuit breaker. Wire with at least 16 gauge wire. Single line-loc applications should be wired according to the "Transbrake" wiring diagram to the left, using your single line-loc solenoid in place of the transbrake solenoid.

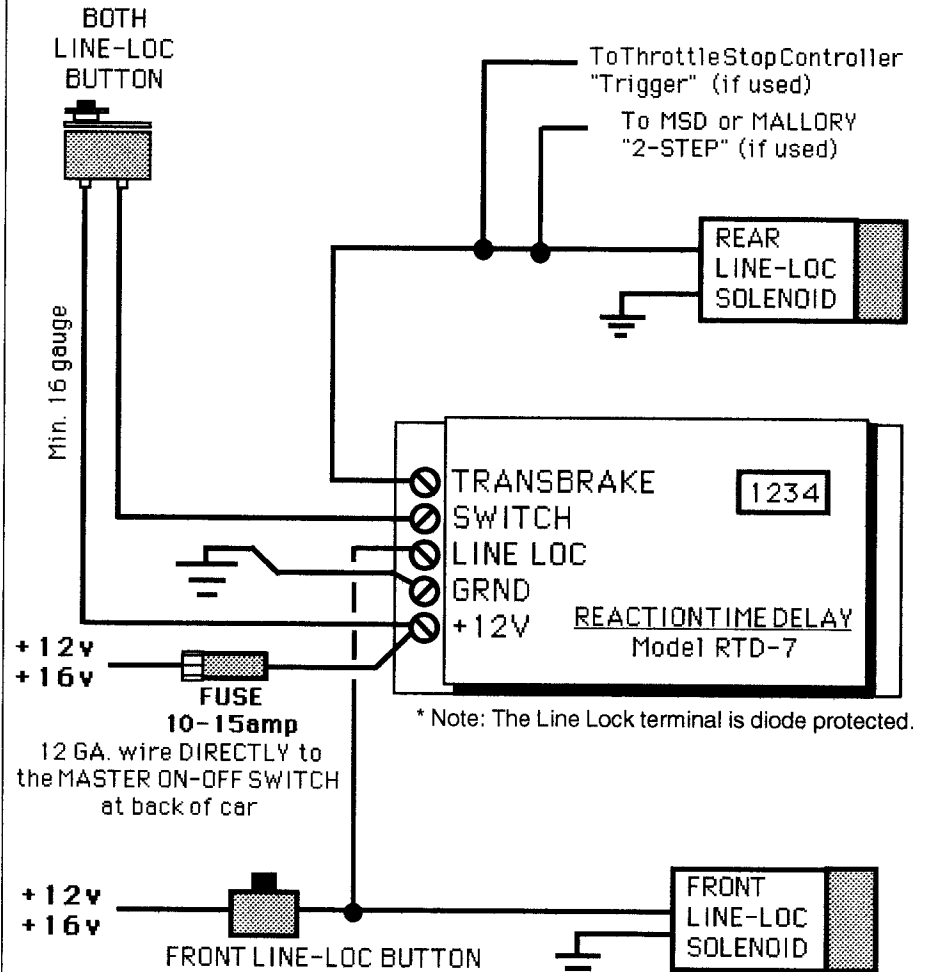

For Technical Information & Assistance, Dial
(925)935-3025