

DYNA III ELECTRONIC IGNITION INSTALLATION INSTRUCTIONS

PART NO. D37-1 FOR 1974 AND LATER MOTO GUZZI MOTORCYCLES
EXCEPT V35 / V50 / V65

The Dyna III Electronic Ignition System has been designed for easy installation and does not require the use of special tools. The compact electronic module operates efficiently and was designed to clamp to a frame tube. It can be located anywhere that there is sufficient space, and does not require special considerations as it is completely vibration and water proof. The recommended location is on the left frame tube under the fuel tank.

The DYNA III System was designed for use with stock coils, however, it may be used with other coils that have at least THREE OHMS primary resistance.

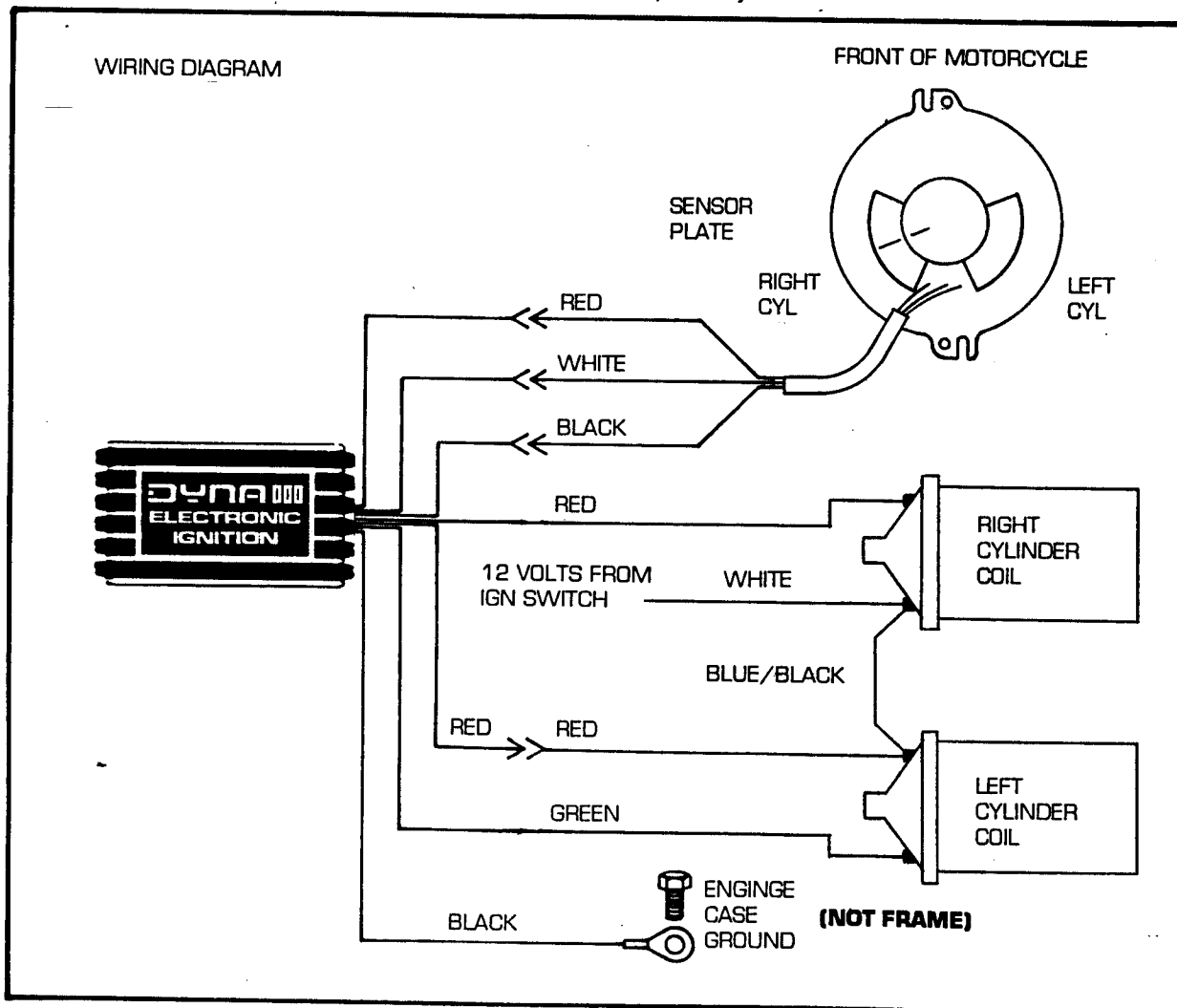

PROCEDURE -

- 1) Fasten the clamp to the electronic module using the 4-40 x 5/16 screws and locknuts provided. The clamp and nuts go on the inside of the case.
- 2) Remove the fuel tank. Attach the module to the frame in the location selected. Cut off excess clamp material.
- 3) Remove an engine case or valve cover bolt and fasten the ground lug (black wire) securely to the engine. DO NOT ATTACH TO FRAME.
- 4) Locate the two ignition coils (they are positioned behind the left side cover on some models). There is a white wire going to the positive side of one coil that carries the switched 12 volts. A short blue/black wire then connects that point to the positive side of the other coil. Connect the separate red wire included with the kit to the spare spade terminal that is available on the positive terminal of the second coil.
- 5) Plug the red wire coming from the electronic module into the red wire installed in Step 4.
- 6) Remove the cap from the contact breaker housing. Remove the alternator cover, timing mark inspection plug, and spark plugs.
- 7) Remove the two screws and clips holding the points plate to the housing. Remove the screws holding the condensers to the housing. Disconnect the red and green wires where they plug into the wire harness (or coils), and remove the entire points/plate/condenser assembly.
- 8) Make sure the top of the housing is clean. Place the DYNA III sensor plate on the housing and orient it so that the wires exit to the rear. Place one of the original wire grommets on the front end of the plate and secure it with the screw and clip previously removed. Route the sensor cable wires through the other grommet (2 wires in the largest hole) and secure with the other screw and clip. Before tightening the plate screws, make sure the plate does not obstruct the cap screw holes.
- 9) Using a hex wrench in the alternator bolt, rotate the engine forward until the right hand cylinder is at top dead center on the compression stroke (D mark aligned with index mark on engine case).
- 10) Make sure the points cam is free of dirt and grease, and slip the DYNA III rotor over the cam. Push the rotor down until its flange is in contact with the top of the cam. Orient the rotor so that the mark on top aligns with the line on the left (right cylinder) sensor. While pushing down on the rotor, tighten the set screws using the allen wrench supplied with the kit.

- 11) Rotate the engine by hand and check run-out (wobble) of rotor by watching the rotor/sensor gap. If the rotor is installed correctly, there should be no more than .005 run-out, and it should not come in contact with either sensor. As a final check, turn the engine with the electric starter and observe the run-out.
- 12) Connect the three sensor cable plugs to the module receptacles, matching the red, white, and black wires.
- 13) Plug the remaining red and green wires onto the spade terminals where the original points connected, matching the colors.
- 14) This completes the wiring. Make sure that all connections are secure and that all colors match.

TIMING-

NOTE:

- A) Refer to owner's manual for additional timing information.
 - B) The left sensor triggers the right cylinder, the right sensor triggers the left cylinder, and each provides $\pm 10^\circ$ of adjustment. Moving them counterclockwise advances the timing and clockwise movement retards the timing.
 - C) All final timing adjustment should be made using the advance timing marks which are the top marks on the flywheel.
 - D) The sensor to rotor air gap is not critical as long as there is no contact between the parts. There should generally be .020 inch between them.
 - E) When setting timing, do not overtighten sensor nuts, as damage may result.
- 1) To time the engine statically, connect a 12 volt test light from the red coil wire to ground. Loosen both housing clamp bolts.
 - 2) Turn ignition switch on. Slowly rotate the engine in the forward direction until the right cylinder retarded (middle) mark aligns with the index mark on the engine case.
 - 3) The light should be off. If it isn't, rotate the housing clockwise until it goes off. Then rotate it counterclockwise until the light comes on.

NOTE: If light remains bright at all times, it indicates that there is a bad connection in the wiring. Ensure that there is 12 volts to the red module wire.

TIMING CONTINUED -

- 4) Rotate the engine backwards until the light goes out, then slowly rotate the engine in the forward direction until the light comes on. The right cylinder retarded (middle) mark should align with the index mark on the engine case.
- 5) If the marks do not align, rotate the housing as appropriate and repeat Step 4. After setting, tighten housing clamp bolts and recheck again.
- 6) After the right cylinder timing is verified, connect the test light to the green coil wire. Slowly rotate the engine in the forward direction until the light comes on. The left cylinder retarded (middle) mark should align with the index mark on the engine case.
- 7) If the marks do not align, loosen the nuts on the right sensor and move it clockwise or counterclockwise as appropriate (.010 inch equals 1°) and gently retighten nuts.
- 8) Rotate the engine backwards until the light goes out, and repeat Step 6.
- 9) To be sure full advance is being obtained, rotate the engine backward and then forward again until the advanced (top) mark aligns with the case index mark. Rotate the DYNA III rotor clockwise against the advance spring. The light should come on just as the limit of travel is reached. If not, rotate the housing (not the sensors) slightly counterclockwise, and recheck.
- 10) The engine can and should be timed using a strobe light in the normal manner. Use the advanced timing marks and an engine speed where full advance is obtained.
- 11) Replace all covers, fuel tank, and spark plugs.

DYNATEK

164 S. VALENCIA ST.
GLENORA, CA 91741
(626) 963-1669
FAX (626) 963-7399