

DYNA 4000 SUPER PRO HIGH ENERGY IGNITION SYSTEM

FOR
FOUR CYLINDER ENGINES

(QUAD OUTPUT MODEL DP4000-2S,
FOR DUAL PLUG HEADS)

This ignition is a quad output model for use with dual plugged heads. This DP4000-2S module may also be used with single plug heads if the three wires that normally go to the second Twinfire coil are simply left unplugged from the second coil (see wiring diagram).

DESCRIPTION

The Dyna 4000 Super Pro is the next generation drag race ignition for motorcycles. The Super Pro is a refinement of the venerable Dyna 4000 Pro. The Super Pro maintains all the excellent features of the Dyna 4000 Pro with the following enhancements:

- * Substantially increased electrical noise immunity.
- * Improved wire harnessing to insure bulletproof operation under all conditions.
- * Compatibility with the new Dyna Remote Display.

The DYNA 4000 Super Pro Ignition is a high energy inductive ignition designed to meet the needs of the professional drag racer. The DYNA 4000 includes a built-in two stage rev limiter that is used for launch control and over rev protection.

The best ignition imaginable for high rpm, high horsepower engine would have a long spark duration and deliver high spark energy. This is exactly what the DYNA 4000 has been designed to accomplish. By using specially designed coils, and special microprocessor based control circuitry to manage the high currents that these coils draw, the DYNA 4000 can deliver four times the spark energy of the most popular CD booster all the way up to 17,000 rpm! These high energy sparks also have the desirable long duration characteristics of inductive ignitions. This translates directly into better engine performance across the board.

The DYNA 4000 is not only a powerful ignition system, but also the smoothest two stage rev limiter available. The DYNA 4000 has a programmable launch limiter activated by a clutch switch to help maintain consistency at the starting line. A programmable over rev limiter is also implemented to prevent engine damage due to drive line breakage or missed shifts. The DYNA 4000 launch system is the choice of world champion drag racers due to its rock steady limiting characteristics. Other popular launch limiters cause engine harming banging and popping due to their unsteady limiting. The DYNA 4000 holds the rpm to a perfectly steady and smooth limit while preparing to launch.

The DYNA 4000 is not just an improvement in available ignition technology for drag racing, it sets a new standard of performance and quality.

DYNATEK

164 S. VALENCIA ST. • GLENDORA, CA 91741 • (626) 963-1669 • FAX (626) 963-7399

INSTALLATION

****IMPORTANT**** On all vehicles, you must always have a heavy ground wire attached from the battery negative post to the engine case. This ground wire should be a 6 gauge wire (1/4" conductor) or larger.

****IMPORTANT**** With any microprocessor based engine system, such as the DYNA 4000, you must use carbon core type suppression spark plug wires with a resistance of at least 3000 ohms per foot to reduce radio frequency interference caused by ignition sparks. Use of copper or spiral core wires may cause malfunction of this ignition system due to severe electrical noise.

****** The DYNA 4000 Pro ignition uses the Dyna Crank Trigger as a pickup signal source. Crank Triggers are available for a number of different engine types. Contact your Dynatek dealer for more information on available part numbers.

****** The DYNA 4000 must be used with DYNATEK #DC9-2, 0.7 ohm Twinfire coil or #DC9-1, 0.7 ohm, blue ignition coils. The DYNA 4000 will not work properly with other coils.

1. Choose a mounting place for the DYNA 4000 that is well away from the ignition coils and spark plug wires. The coils are a source of intense magnetic interference which can cause erratic operation of sensitive electronics. The most common ignition placement is under the seat. The Dyna 4000 Super Pro can be mounted using the four 10-32 screws located on the bottom of the module. Simply screw the module to a sheet metal plate. If you do not use the mounting screws, leave them in the module housing.

2. Locate the main wiring harness included with the kit. Plug the large 21 position harness connector into the 4000 SP ignition module.

*****Refer to the included system wiring diagram during the following steps**

3. Mount the DC9-2 Twinfire coils close to the spark plugs to minimize spark plug wire length. The Twinfire coils contains two separate ignition coils in one easy to mount package (see wiring diagram). The two spark plug towers on the left side of each coil fire cylinders 1 and 4. The two spark plug towers on the right side of each coil fire cylinders 2 and 3. Connect carbon core spark plug wires from the output towers of the coils to the spark plugs in the appropriate arrangement. Each ignition coil must always feed two cylinders as shown on the coil wiring diagram. In other words the 1/4 section of a coil must have one spark plug wire attached to cylinder 1 and one spark plug wire to cylinder 4. Never attach both spark plug wire towers of one coil section to a single cylinder.

4. Locate the unterminated six wire leg of the main harness that has blue, white, yellow, purple, and two red wires at the loose end. This is the coil wire group. Route this portion of the harness to the ignition coil. It is best to route this leg of the harness away from other vehicle wiring since it will carry noisy coil currents.

5. Locate the black three position plug housing and female spade terminals that came with each Twinfire coil. Trim the main harness coil wires to length. Install the female spade terminals onto the wire ends. Plug the spade terminals into the three position housing such that the wire colors mate with similar colors on the coil plug; i.e. red to red, white to white, and blue to blue on one Twinfire coil. For the second Twinfire coil connect red to red, yellow to white and purple to blue as shown in the wiring diagram. Connect the newly installed plug housing to the Twinfire coil plug.

6. Find the four wire leg of the main harness that has red/black, black/white, blue/black, and white/black wires going to a flat four position plug. This is the crank trigger group. Route this leg of the harness toward the crank trigger location on the engine. Connect these wires to the Crank Trigger plug.

7. Find the unterminated four wire leg of the main harness that has red/white, purple/white, green and brown wires at the loose end. Route this leg of the harness to the handle bar area. The red/white and purple/white wires are the clutch switch wires. Connect these wires to a normally-open clutch switch. When the clutch switch contacts are closed (clutch lever pulled in) the low rev limit will be active. The low limit can be also be activated by feeding a source of 12 volts to the purple/white wire. This makes it easy to use a three terminal clutch switch to activate the low rev limiter when the clutch is pulled in and activate a nitrous unit or other device when the clutch lever is released.

The green wire is a two pulse per revolution tach output which can be used to trigger a tach, data recording computer, shift light etc. The brown wire is the ignition enable wire. 12 volts from the ignition switch must be connected to the brown wire to enable ignition operation. The 4000 Super Pro has been designed such that if you have a faulty ignition switch which experiences contact bounce while you go down the track the ignition will not miss a beat. The ignition switch contacts must be open for more than 1/3 of a second for the ignition to actually be disabled.

8. If you wish to use an air kill switch to interrupt the ignition during shifts, complete the following: Find the unterminated two wire leg of the main harness that has an orange and black wire at the loose end. The orange and black wires should be connected to either side of the air kill switch. Use the switch contacts that are normally open. When the switch contacts close, connecting the black and orange wires, the ignition will be interrupted. No other wires should be connected to the air kill switch. Do not run +12v ignition power through the air kill switch as you would with other systems.

9. Locate the black and red 12 gauge power wires that extend directly from the Dyna 4000 Super Pro module. These wires must be connected directly to the battery using the included pigtail. Connect red to the positive post of the battery and black to the negative post. Trim the power wires to length and install the included 1/4" ring terminals onto the wires such that they can be installed onto the battery terminals.

10. Whether you are using a Dyna S ignition as a pickup or using a Dyna Crank Trigger make sure you have installed the special blue two magnet rotor on the crankshaft or the Dyna 4000 will not work properly. The extra magnet is located 90 degrees ahead of the normal firing magnet as seen by the pickups when the crankshaft is rotating. There should be a mark on the top of the special rotor indicating its type:

- 3P - DYNA 4000 Kawasaki KZ
- 6P - DYNA 4000 Suzuki GS
- other models are also available

11. After the main harness has been installed and the Crank Trigger and two magnet crankshaft rotor are in place and the 0.7 ohm Twinfire coil has been installed, you are ready to static time the motor. Apply +12V power to the DYNA 4000 by turning on the ignition switch. While slowly turning the crankshaft in its normal forward direction with a wrench, watch the red LED lamp located on the end of the DYNA 4000. When either magnet of the Crank Trigger rotor passes in front of one of the sensor modules, the red LED will light. This indicates the switching action of the pickup. When the crankshaft is turned in its normal forward direction, the first magnet to pass a Crank Trigger sensor is the 90 degree lead magnet. Do not static time off this magnet. Static timing must be checked when the second magnet comes near the sensor, at the point where the LED first comes on.

12. You should be able to start the motor at this point. If the motor will not start, check that you are getting +12V to the red wire at the coil and to the brown ignition enable wire and check all other wiring. If it still doesn't start, you may have the Crank rigger rotor on backwards.

USING YOUR DYNA 4000 SYSTEM

You should have your system completely installed at this point, and the motor timed and ready to run. Locate the two knobs on the end of the DYNA 4000 ignition module. These are used to set the rev limiters. Adjust the left knob according the legend to set the low side launch limit to the desired rpm. Adjust the right knob according to the legend to set the high side over rev limit. Both rev limiters are adjustable in 250 rpm

DYNA 4000 SUPER PRO - QUAD SYSTEM COIL WIRING

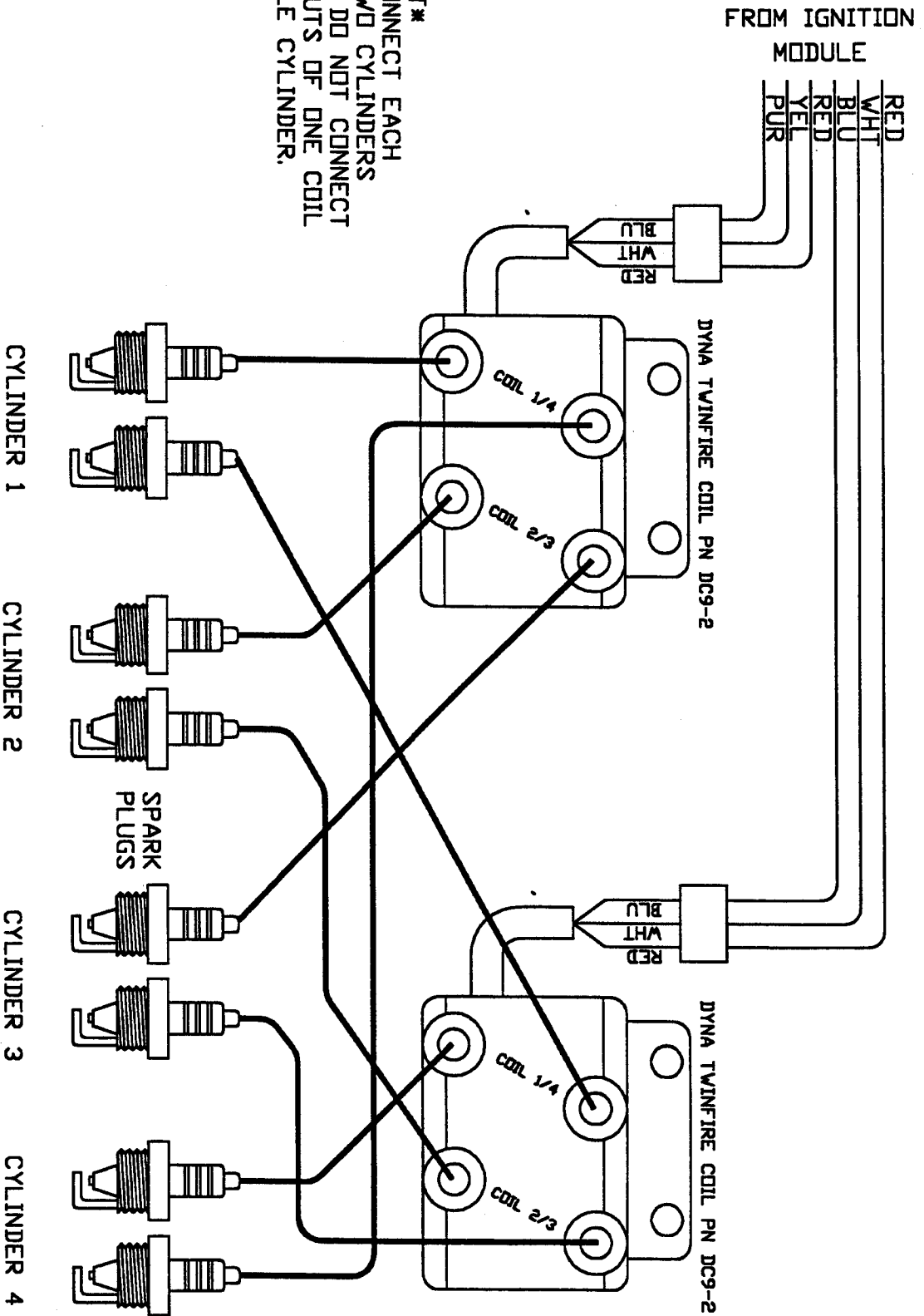

IMPORTANT
ALWAYS CONNECT EACH
COIL TO TWO CYLINDERS
AS SHOWN. DO NOT CONNECT
BOTH OUTPUTS OF ONE COIL
TO A SINGLE CYLINDER.

DYNATEK	
164 S. VALENCIA ST., GLENDALE, CA 91741 (818)263-1669	
TITLE DYNA 4000 QUAD COIL WIRING	
DATE 1-14-98	DRAWING NO. D4K4COIL.DWG
	REV 3.1

DYNA 4000 SUPER PRO - QUAD SYSTEM WIRING

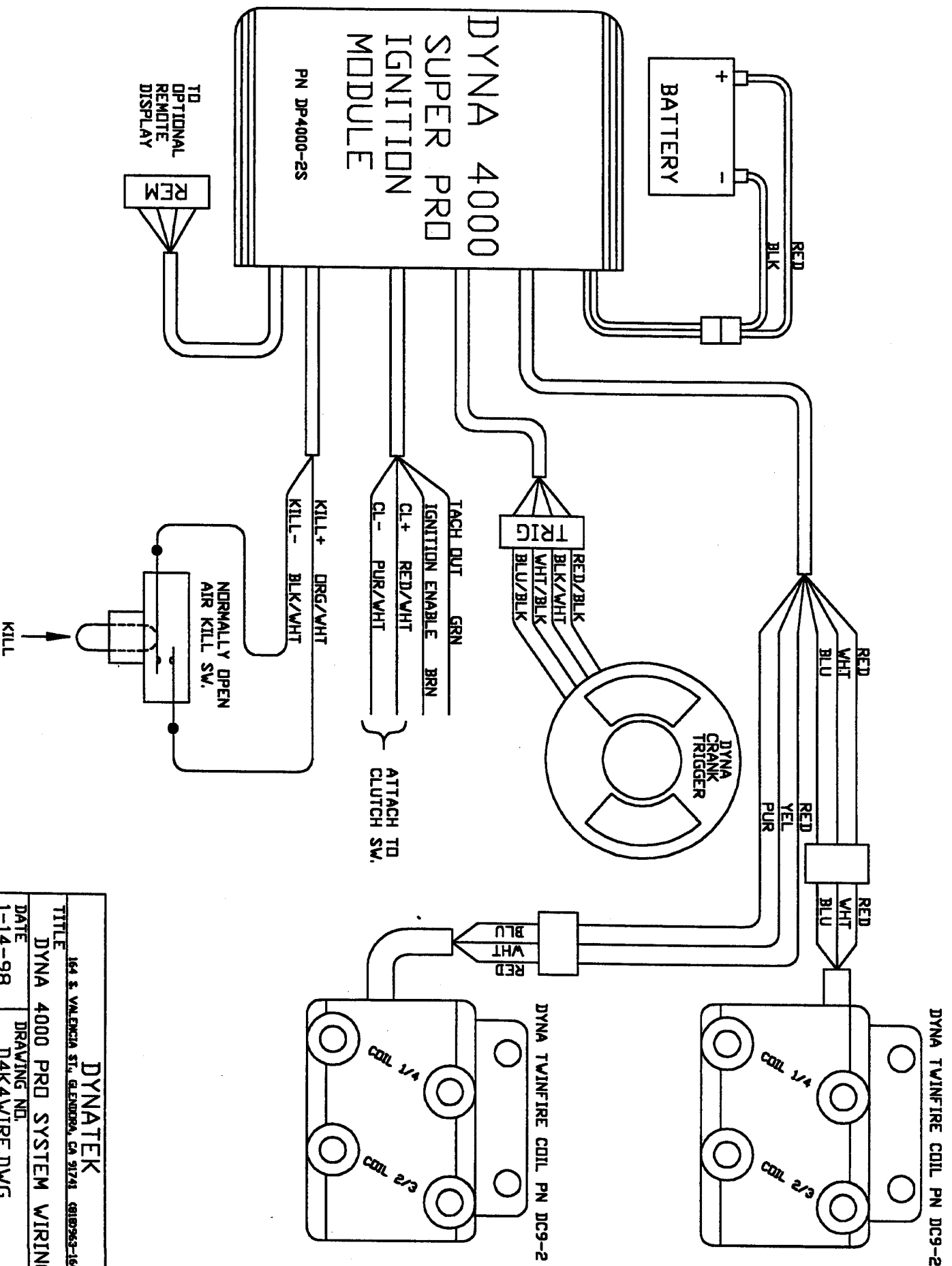

DYNATEK		REV
164 S. VALENCIA ST., GLENHOLM, CA 91741 918263-1663		3.1
TITLE	DYNA 4000 PRD SYSTEM WIRING	
DATE	1-14-98	
DRAWING NO.	D4K4WIRE.DWG	