

DYNA 4000 SUPER PRO HIGH ENERGY IGNITION SYSTEM FOR HARLEY-DAVIDSON ENGINES

(DUAL OUTPUT MODEL DP4000-HD1S, FOR SINGLE
PLUGGED HEADS ONLY)

This ignition is a dual output model for use with single plugged heads only. For dual plugged heads use the quad output DP4000-HD2S ignition module.

DESCRIPTION

The Dyna 4000 Super Pro is the next generation drag race ignition for motorcycles. The Super Pro is a refinement of the venerable Dyna 4000 Pro. The Super Pro maintains all the excellent features of the Dyna 4000 Pro with the following enhancements:

- * Substantially increased electrical noise immunity.
- * Improved wire harnessing to insure bulletproof operation under all conditions.
- * Compatibility with the new Dyna Remote Display.

The DYNA 4000 Super Pro Ignition is a high energy inductive ignition designed to meet the needs of the professional drag racer. The DYNA 4000 includes a built-in two stage rev limiter that is used for launch control and over rev protection.

The best ignition imaginable for a high rpm, high horsepower engine would have a long spark duration and deliver high spark energy. This is exactly what the DYNA 4000 has been designed to accomplish. By using specially designed coils, and special microprocessor based control circuitry to manage the high currents that these coils draw, the DYNA 4000 can deliver four times the spark energy of the most popular CD booster all the way up to 17,000 rpm! These high energy sparks also have the desirable long duration characteristics of inductive ignitions. This translates directly into better engine performance across the board.

The DYNA 4000 is not only a powerful ignition system, but also the smoothest two stage rev limiter available. The DYNA 4000 has a programmable launch limiter activated by a clutch switch to help maintain consistency at the starting line. A programmable over rev limiter is also implemented to prevent engine damage due to drive line breakage or missed shifts. The DYNA 4000 launch system is the choice of world champion drag racers due to its rock steady limiting characteristics. Other popular launch limiters cause engine harming banging and popping due to their unsteady limiting. The DYNA 4000 holds the rpm to a perfectly steady and smooth limit while preparing to launch.

The DYNA 4000 is not just an improvement in available ignition technology for drag racing, it sets a new standard of performance and quality.

DYNATEK

164 S. VALENCIA ST. • GLENDORA, CA 91741 • (626) 963-1669 • FAX (626) 963-7399

INSTALLATION

****IMPORTANT**** On all vehicles, you must always have a heavy gauge ground wire attached from the battery negative post to the engine case. This ground wire should be a 6 gauge wire (1/4" conductor) or larger.

****IMPORTANT**** With any microprocessor based engine system, such as the DYNA 4000, you must use carbon core type suppression spark plug wires with a resistance of at least 3000 ohms per foot to reduce radio frequency interference caused by ignition sparks. Use of copper or spiral core wires may cause malfunction of this ignition system due to severe electrical noise.

****** The DYNA 4000-HD1S Super Pro ignition uses the DYNA Crank Trigger, part number DCT-HD, as a pickup signal source. On Harley-Davidson motors, the Crank Trigger mounts on the camshaft in the standard ignition pickup location.

****** The DYNA 4000 must be used with DYNATEK #DC9-2, or DC9-3, 0.7 ohm Twinfire coils or DYNA #DC9-1, 0.7 ohm, blue ignition coils. The DYNA 4000 will not work properly with other coils.

SINGLE FIRE/DUAL FIRE CONSIDERATIONS

A Harley ignition can take two basic forms, dual fire or single fire. In a dual fire system, the outputs of one dual output coil are connected to the spark plugs of both cylinders. In a single fire system, two coils are used. In single fire, each coil feeds only one cylinder. The DYNA 4000 can be used in either dual fire or single fire mode.

COILS

For single fire w/single plugged heads you need one DC9-3 Twinfire coil ; for dual fire w/single plugged heads you need one DC9-1 blue coil.

1. Choose a mounting place for the DYNA 4000 that is well away from the ignition coils and spark plug wires. The coils are a source of intense magnetic interference which can cause erratic operation of sensitive electronics. The most common ignition placement is under the seat near the rear tire. Mount the module using the four 10-32 screws on the bottom of the module. If you do not use the 10-32 screws for mounting purposes, leave them in the module.

2. Locate the main wiring harness included with this kit. Plug the 21 position white harness connector into the 4000 SP module.

For dual fire installation skip down to step DF 3 ('DUAL FIRE INSTALLATION').

SINGLE FIRE INSTALLATION (separate coil for each cylinder)

NOTE The DC9-3 Twinfire coil contains two separate ignition coils in one easy to mount package.

SF 3. Mount the DC9-3 Twinfire coil close to the spark plugs to minimize spark plug wire length. One of the coil spark plug wire towers will feed the front cylinder and the other tower will feed the rear cylinder (refer to the wiring diagram). Connect carbon core spark plug wires from the output towers of the coil to the spark plugs.

*****Refer to the included system wiring diagram during the following steps**

SF 4. Locate the three wire unterminated leg of the main harness that contains red, white, and blue wires. This is the coil wire group. Extend these coil wires from the ignition module up to the coil mounting location. It is best to route these wires away from other vehicle wires since they carry high voltage pulses. Locate the three spade terminals and three position black connector housing that came with the Twinfire coil. Trim the 4000 wires to length and install the spade terminals onto the ends of the three coil wires. Insert the three terminated wires into the black plug housing such that the colors will match across the plug when you connect it to the

Twinfire coil, i.e. red to red, white to white, and blue to blue.

Skip to 'SINGLE OR DUAL FIRE CONTINUED'

DUAL FIRE INSTALLATION (one coil for both cylinders)

DF 3. Mount the DC9-1 coil close to the spark plugs to minimize spark plug wire length. Connect carbon core spark plug wires from the output towers of the coil to the spark plugs.

***Refer to the included system wiring diagram during the following steps

DF 4. Locate the three wire unterminated leg of the main harness that contains red, white, and blue wires. This is the coil wire group. Extend these coil wires from the ignition module up to the coil mounting location. It is best to route these wires away from other vehicle wires since they carry high voltage pulses. Using the ring terminals supplied with the kit, connect the red wire to one of the primary screw terminals on the coil. Connect the blue and white wires together and attach them to the remaining primary screw terminal on the coil as shown in the wiring diagram.

SINGLE OR DUAL FIRE CONTINUED

5. Find the four wire leg of the main harness that has red/black, black/white, blue/black, and white/black wires going to a flat four position plug. This is the crank trigger group. Route this leg of the harness toward the crank trigger location on the engine. Connect these wires to the Crank Trigger plug.

6. Find the unterminated four wire leg of the main harness that has red/white, purple/white, green and brown wires at the loose end. Route this leg of the harness to the handle bar area. The red/white and purple/white wires are the clutch switch wires. Connect these wires to a normally-open clutch switch. When the clutch switch contacts are closed (clutch lever pulled in) the low rev limit will be active. The low limit can be also be activated by feeding a source of 12 volts to the purple/white wire. This makes it easy to use a three terminal clutch switch to activate the low rev limiter when the clutch is pulled in and activate a nitrous unit or other device when the clutch lever is released.

The green wire is a two pulse per revolution tach output which can be used to trigger a tach, data recording computer, shift light etc. The brown wire is the ignition enable wire. 12 volts from the ignition switch must be connected to the brown wire to enable ignition operation. The 4000 Super Pro has been designed such that if you have a faulty ignition switch which experiences contact bounce while you go down the track the ignition will not miss a beat. The ignition switch contacts must be open for more than 1/3 of a second for the ignition to actually be disabled.

7. If you wish to use an air kill switch to interrupt the ignition during shifts, complete the following: Find the unterminated two wire leg of the main harness that has orange/wht and black/wht wires at the loose end. The orange and black wires should be connected to either side of the air kill switch. Use the switch contacts that are normally open. When the switch contacts close, connecting the black and orange wires, the ignition will be interrupted. No other wires should be connected to the air kill switch. Do not run +12v ignition power through the air kill switch as you would with other systems.

8. Locate the black and red 12 gauge power wires that extend directly from the Dyna 4000 Super Pro module. These wires must be connected directly to the battery using the included pigtail. Connect red to the positive post of the battery and black to the negative post. Trim the power wires to length and install the included 1/4" ring terminals onto the wires such that they can be installed onto the battery terminals.

9. Whether you are using a Dyna S ignition as a pickup or using a Dyna Crank Trigger make sure you have installed the special blue two magnet rotor on the crankshaft or the Dyna 4000 will not work properly. The extra magnet is located 90 degrees ahead of the normal firing magnet as seen by the pickups when the camshaft is rotating. There should be a mark on the top of the special rotor indicating its type:

HP = Harley-Davidson 4000 rotor

10. After the main harness has been installed and the Crank Trigger and two magnet camshaft rotor are in place and the 0.7 ohm coil has been installed, you are ready to static time the motor. Apply +12V power to the DYNA 4000 by turning on the ignition switch. While slowly turning the crankshaft in its normal forward direction with a wrench, watch the red LED lamp located on the end of the DYNA 4000. When either magnet of the Crank Trigger rotor passes in front of one of the sensor modules, the red LED will light. This indicates the switching action of the pickup. When the crankshaft is turned in its normal forward direction, the first magnet to pass a Crank Trigger sensor is the 90 degree lead magnet. Do not static time off this magnet. Static timing must be checked when the second magnet comes near the sensor, at the point where the LED first comes on.

11. You should be able to start the motor at this point. If the motor will not start, check that you are getting +12V to the red wire at the coil and to the brown ignition enable wire and check all other wiring.

USING YOUR DYNA 4000 SYSTEM

You should have your system completely installed at this point, and the motor timed and ready to run. Locate the two knobs on the end of the DYNA 4000 ignition module. These are used to set the rev limiters. Adjust the left knob according to the legend to set the low side launch limit to the desired rpm. Adjust the right knob according to the legend to set the high side over rev limit. Both rev limiters are adjustable in 250 rpm increments.

The DYNA 4000 reads the settings of the rpm limit switches only when the unit is first turned on. In other words, if you make an adjustment to one of the rev limit switch settings while the ignition power is on, you must turn off power to the DYNA 4000 then reapply power for the new switch settings to be recognized.

When you have the clutch lever pulled in you should be able to rev the motor up to the preset low side limit and slowly roll the throttle wide open. The limiter should hold the motor to the desired rpm until the clutch lever is released, then the high side limit will take over.

OPTIONAL REMOTE DISPLAY

The Dyna 4000 Super Pro ignition can be used with the new Dyna Remote Display part number DRD-1. The Remote Display allows you to set both rev limiters over a much wider range, from 2000 to 16,000 rpm, in 200 rpm increments. Rev limit adjustment can also be done while the engine is running, at the starting line. The Remote Display also gives a real time rpm indication and a clutch switch status indicator. The Remote Display is designed to easily mount to the handle bar area of the bike, and has easy to use control switches on its front panel. The Remote Display also has a 'test mode' which allows you to test the ignition without the engine running. You can actually simulate any rpm with the test mode to test not only the ignition, but all other rpm activated devices attached to the ignition. In test mode the coils actually fire and the tach output is active at an rpm you can control from the Remote Display control switches.

The Dyna 4000 Super Pro harness is already outfitted with a connection for the Remote Display. The flat four position plug with black/white, white/red, grey, and orange wires allows you to simply plug in a Remote Display to take advantage of these features.

Contact your Dynatek dealer or distributor for more information on the Remote Display.

DYNA 4000 SUPER PRO - SYSTEM WIRING SINGLE FIRE W/SINGLE PLUG

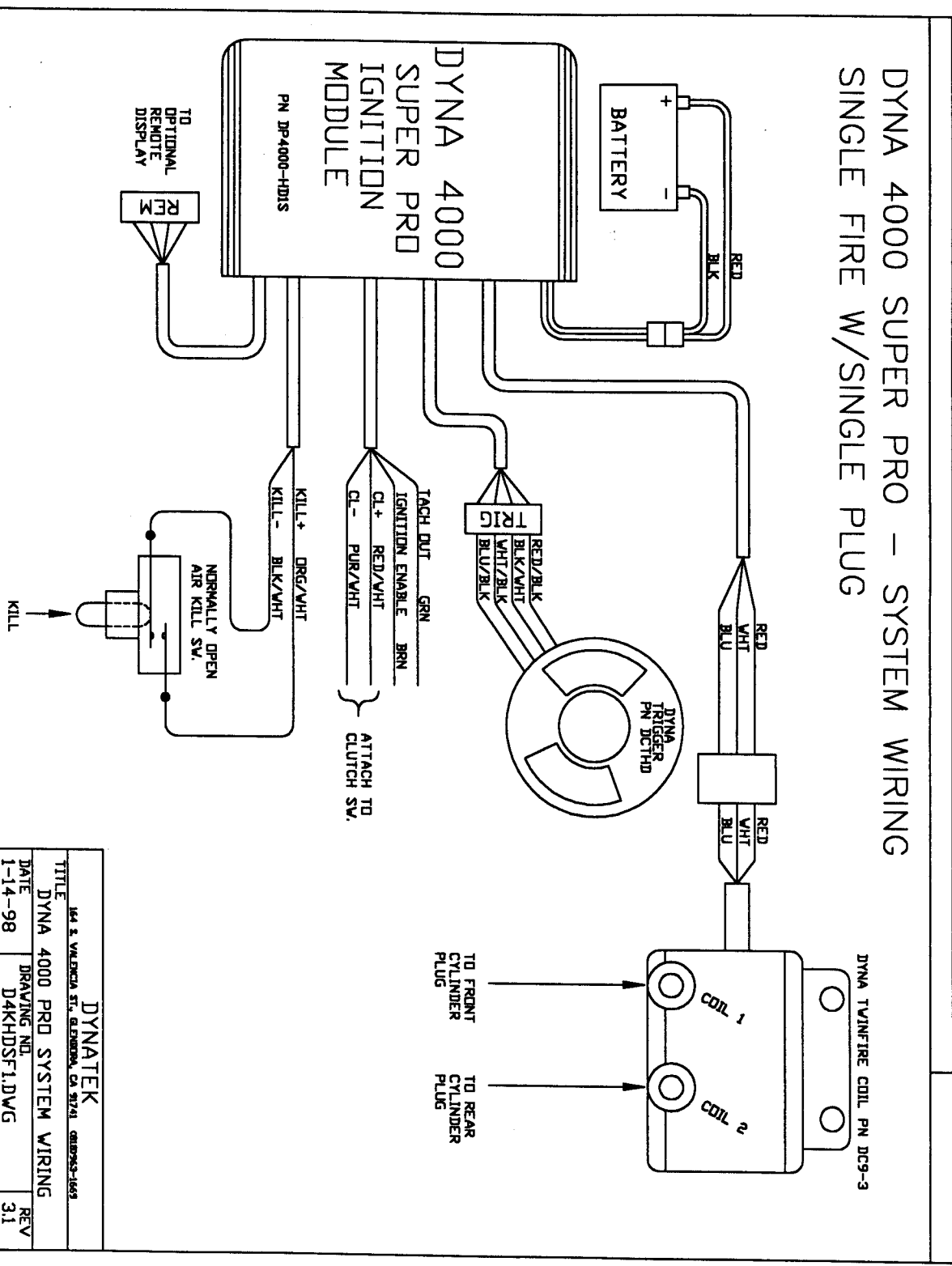

DYNATEK	
<small>144 S. VALENCIA ST., GLENDALE, CA 91201, (818) 241-1653</small>	
TITLE	DYNA 4000 PRD SYSTEM WIRING
DATE	1-14-98
DRAWING NO.	DAKHDSF1.DWG
REV	3.1

DYNA 4000 SUPER PRO - SYSTEM WIRING DUAL FIRE W/SINGLE PLUG

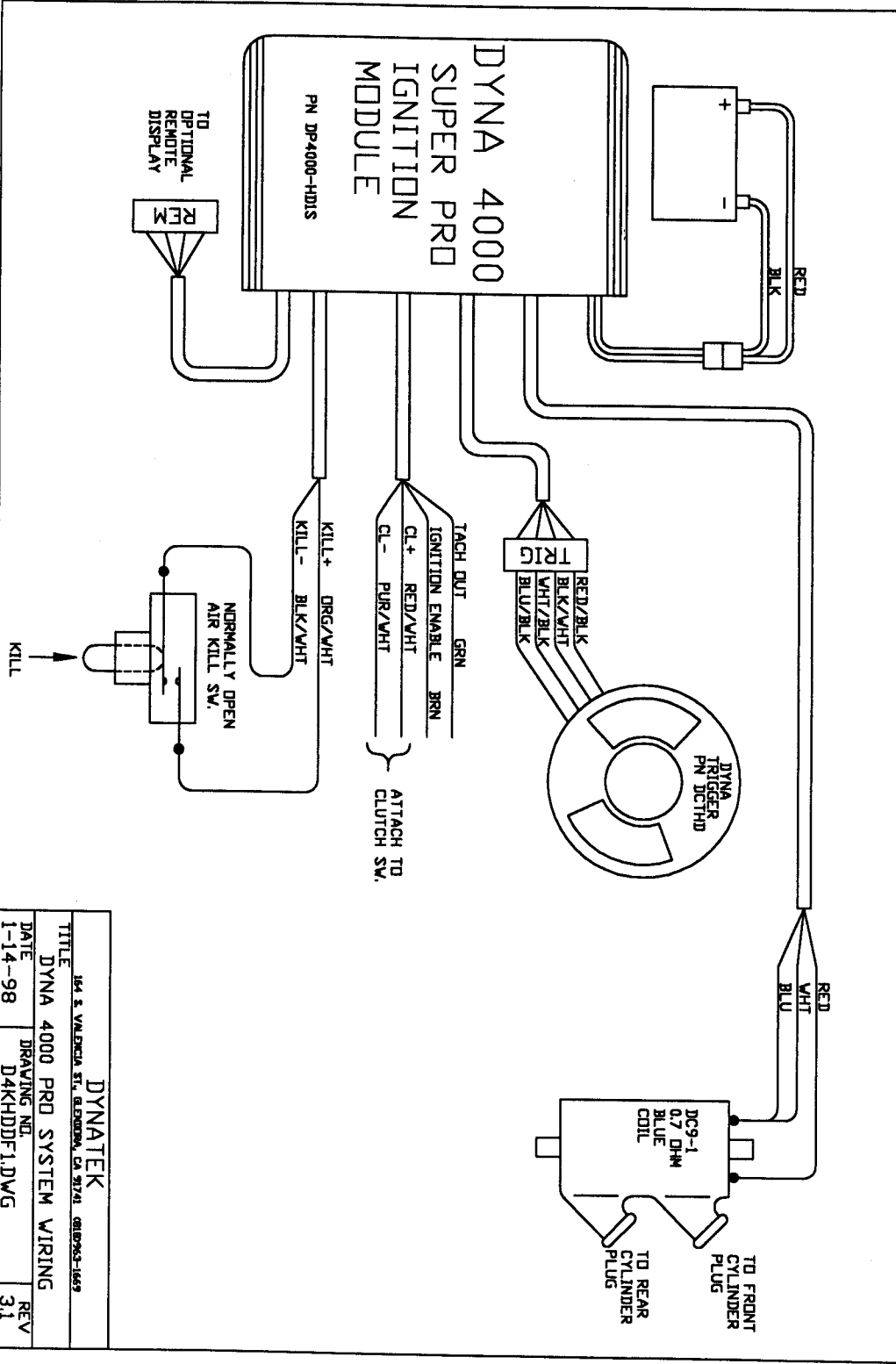

DYNATEK	
164 S. VALENCIA ST., SHERBORN, CA 91761. (818)963-1665	
TITLE	DYNA 4000 PRD SYSTEM WIRING
DATE	1-14-98
DRAWING NO.	D4KHDDF1.DWG
REV	3.1