

### **MPS Dry Nitrous Kit For Fuel Injected Motorcycles Instructions**

The **MPS Dry Nitrous Kit** was designed to easily increase horsepower of a fuel injected motorcycle. These Dry Nitrous Kits exploit the ability of electronic fuel injection to deliver extra fuel at a touch of a button. The kits yield between 20 and 40 + horsepower. They are strictly for fuel injected motorcycles. The MPS Dry Nitrous Kit For Fuel Injected Motorcycles is for use in closed course competition events only and are not for use on any public street or highway.

**Mounting** – To mount the bottle you will need to find a suitable spot. **Danger: Nitrous bottles can explode. Never exceed 1000 lbs of bottle pressure. Nitrous pressures over 1000 lbs or so can prevent the nitrous solenoid from opening. Do not expose the bottle to direct sunlight or leave the bottle enclosed in a container in direct sunlight. If you mount your bottle in your trunk or under the seat be sure to take the bottle out before letting the bike sit in the sun. Nitrous gains pressure with temperature. Do not mount the bottle near any source of heat. You will need to find a place that the bottle is out of sight, away from heat, secure, and accessible. Above the motor, under the tank is not a good spot in other words!** The nitrous bottle has no siphon tube installed in the bottle.

When the bottle is mounted the valve should be the lowest part of the bottle. The better job you can do positioning your bottle the better the system will function. The system needs to pick up liquid nitrous. The optimum position is the bottle valve toward the ground.

Siphon tubes can be installed if you wish to mount the bottle upright. Mount the nitrous nozzle in a ram air tube at the front of the airbox. With the nitrous nozzle in this location the nitrous will pass through the air filter. To install the nozzle mount in the ram air tube, drill a 7/16" hole where you want your nitrous nozzle mounted. Push the bolt half of the nozzle mount through the hole from the inside. Screw the nut half of the nozzle mount on from the outside to complete the nozzle mount installation. Screw in the nitrous nozzle till snug, then turn enough to aim it directly at the airbox.

**Plumbing** – The Nitrous solenoid inlet port is connected directly to the nitrous supply bottle via a #4 AN swivel type fitting. Locate the push in style fitting on the "out" side of the nitrous solenoid. Cut the end of the 1/8" high pressure line provided squarely using a razor blade or plastic tubing cutter. Push the line as far into the fitting as it will go. Pull out to lock the line in place. To remove the line from the fitting, push down on the retaining ring on the fitting and the line. While holding down the retaining ring pull the line out of the fitting. Route the line to the nitrous nozzle following existing wiring whenever possible. Make sure you route this line away from any extreme heat. It will melt! Slide the blue b-nut over the line with the thread facing the nozzle side of the line. Next slide the cone ferrule onto the line with the cone facing the nozzle end of the line. Cut the end of the line to the final length squarely with a razor blade or tubing cutter. Push the end of the line securely into the funnel portion of the #28 jet. Insert the jet into the nitrous nozzle and snug the b-nut then turn it about a 1/2 to 1 full turn to secure the jet and line to the nitrous nozzle.



**Wire The Horn/Shifter – Starter/Nitrous Control Box**

*Note: The Black, White, and Blue will not be used if you don't have an air shifter or your bike has a horn that switches power. The switch swapper will only work for air shifters on bikes that switch ground with the horn button.*

- Locate the harness coming out of your left handlebar switch pod.
- Carefully slice back the protective covering around the harness in a convenient spot. Locate the horn switch wire. Hayabusa will be the solid black wire. ZX12 will be a black wire with a white tracer. Other models consult your service manual or call us.
- Cut this wire.
- **Black Wire** - Locate the end that runs to the switch and connect it to the black wire on the controller harness
- **White Wire** - Locate the end that goes toward the main wire harness and connect it to the white wire on the controller
- **Blue Wire** - Connect the blue wire to the blue wire on the MPS Sport Bike Electronic Engine Kill and the negative side of the electric air valve as shown in the wire diagram.
- Locate the harness coming out of your right handlebar switch pod.
- Carefully slice back the protective covering around the harness in a convenient spot. Locate the starter switch wire. Hayabusa and GSXR1000 will be a yellow wire with a green tracer. ZX12 will be a blue wire with a white tracer. Other models consult your service manual or call us.
- Cut this wire.
- **Yellow Wire** - Locate the end that runs to the switch and connect it to the yellow wire on the controller harness
- **Orange Wire** - Locate the end that goes toward the main wire harness and connect it to the orange wire on the controller
- **Red Wire** - Connect the red wire to the nitrous solenoid positive as shown in the wire diagram.

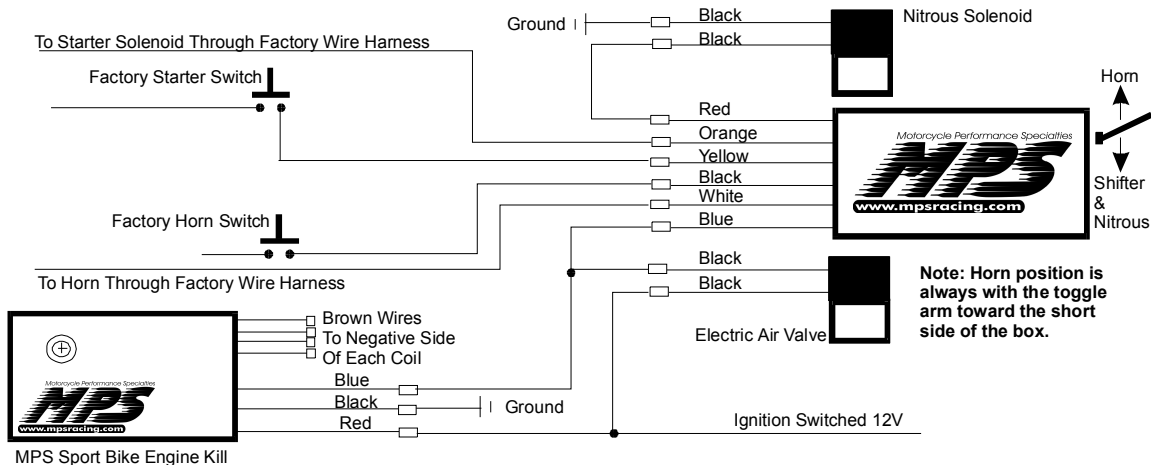

**Wiring Diagram**



***Innovative Racing Electronics***

---

**Factory Horn Switch Wire Colors**

Hayabusa = Solid Black

ZX12R = Black with White tracer

**Factory Starter Switch Wire Colors**

Hayabusa = Yellow with Green tracer

ZX12R = Blue with White tracer

**Note:** To prevent harmful operation of the nitrous when rev limiter is engaged we recommend a MSD RPM P/N 2-15-00-0550 switch. Check with us for proper calibration for your application. You may also need a Tach adapter P/N 1-0271 as well. Wire the red on the rpm switch to ignition switched 12 volt power, the black on the rpm switch to ground, the white on the rpm switch to the tach adapter white, and the tach adapter four greens to the negative side of each coil. Next you will replace the ground lead on the Horn/Nitrous Control with the gray wire on the rpm switch. The gray wire should be the only source of ground for the nitrous solenoid.

**Testing The System** – First, turn of the nitrous bottle valve. Now turn on the key and arm the nitrous. With your hand on the nitrous solenoid, push the starter button quickly. You should hear and feel the nitrous solenoid open. Next flip the nitrous arm switch to the starter position and push the starter button. This should engage the starter and not activate the nitrous solenoid.

**Operation** – The nitrous bottle weighs 2.2 lbs. empty and 3.2 lbs.full. Weighing the bottle is the only way to tell if the bottle is full or empty. Pressure is not an indicator of how much nitrous is left in the bottle. We highly recommend dynoing your bike before taking it to the track. Here are a few tips to tuning and operating the system. Never use the nitrous at anything other than full throttle operation. You will need a minimum of 90 octane fuel. Do not use any product that advances the ignition timing more than stock. A Power Commander is recommended to deliver extra fuel at full throttle. Starting as rich is the safest tuning method. Damage can result when the rev limiter is activated while on nitrous. Avoid the rev limiter on nitrous or install the RPM switch to prevent it from happening. Use of the larger included nitrous jets should be done only after the smaller jets are used successfully.

If you have any more questions we have a Frequently Asked Questions page at our web site as well as the telephone tech support. Thank you for your purchase of this MPS product. All products sold by MPS are for use at closed course competition events and not for use on public streets or highways.

**Phone: 321.972.8282 – Fax: 321.972.5123  
380 Orange Lane – Casselberry, Florida 32707**